

.7hp Vacuum Router

Straight-Line/Rear Exhaust

Air Tool Manual – Safety, Operation and Maintenance

SAVE THIS DOCUMENT, EDUCATE ALL PERSONNEL

Models:

- 51332** – 20,000 RPM
1/4" Collet, 3-1/2in. Base
1in. Vacuum Port Connection
- 51333** – 20,000 RPM
1/4" Collet, 4in. Base
1in. Vacuum Port Connection



Model 51333 Shown

⚠ WARNING

Read and understand this tool manual before operating your air tool. Follow all safety rules for the protection of operating personnel as well as adjacent areas. Always operate, inspect and maintain this tool in accordance with the American National Safety Institute (ANSI) Safety Code for Portable Air Tools – B186.1. For additional safety information, refer to Safety Requirements for the Use, Care and Protection of Abrasive Wheels – ANSI B7.1, Code of Federal Regulation – CFR 29 Part 1910, European Committee for Standards (EN) Hand Held Non-Electric Power Tools – Safety Requirements and applicable State and Local Regulations.

SAFETY LEGEND

	⚠ WARNING Read and understand tool manual before work starts to reduce risk of injury to operator, visitors, and tool.	⚠ WARNING Practice safety requirements. Work alert, have proper attire, and do not operate tools under the influence of alcohol or drugs.	
	⚠ WARNING Eye protection must be worn at all times, eye protection to conform to ANSI Z87.1.	⚠ WARNING Ear protection to be worn when exposure to sound, exceeds the limits of applicable Federal, State or local statues, ordinances and/or regulations.	
	⚠ WARNING Respiratory protection to be used when exposed to contaminants that exceed the applicable threshold limit values required by law.	⚠ WARNING Air line hazard, pressurized supply lines and flexible hoses can cause serious injury. Do not use damaged, frayed or deteriorated air hoses and fittings.	

⚠ WARNING

Some dust created by sanding, grinding, drilling, and other construction activities contain chemicals known to cause cancer, birth defects or other reproductive harm. Some examples of these chemicals are:

- Lead from lead-based paints
- Crystalline silica from bricks and cement and other masonry products
- Arsenic and chromium from chemically treated lumber

Your risk from these exposures varies, depending on how often you do this type of work. To reduce your exposure to these chemicals: work in a well ventilated area, and work with approved safety equipment, such as those dust masks that are specially designed to filter out microscopic particles.

SAFETY INSTRUCTIONS

Carefully Read all instructions before operating or servicing any Dynabrade® Abrasive Power Tool.

Products offered by Dynabrade are not to be modified, converted or otherwise alerted from the original design without expressed written consent from Dynabrade, Inc.

Tool Intent: Handheld vacuum routers are used for cutting and shaping. Ideal for use on wood, solid surfaces, plastics, laminate trimming, surface planing, beveling, and cornering. An appropriate external vacuum source is required that is suitable for material being processed.

Do Not use tool for anything other than its intended applications.

This power tool is not intended for use in potentially explosive atmospheres and is not insulated against contact with electrical power.

Training: Proper care, maintenance, and storage of your tool will maximize its performance.

- Employer's Responsibility – Provide router operators with safety instructions and training for safe use of tools and accessories.

Accessory Selection:

- Accessory RPM (speed) rating MUST be approved for AT LEAST the tool RPM rating.
- Before mounting an accessory, visually inspect for defects. Do not use defective accessories.
- Never use dull or damaged bits. Sharp bits must be handled with care. Damaged bits can snap during use.
- Follow tool specifications before choosing size and type of accessory.
- Only use recommended fittings and air line sizes. (See tool Machine Specifications table.)
- USE ONLY accessories of the correct shaft size for the collet. (Example: 1/4" shaft = 1/4" collet)
- Never use bits that have a cutting diameter greater than the opening in the router base. (1" diameter.)
- DO NOT operate with out vacuum router base in place.
- DO NOT touch router bits after use – extremely hot.
- DO NOT use – cut-off wheels, and saw blades.

OPERATING INSTRUCTIONS

Warning: Always wear eye protection. Operator of tool is responsible for following: approved eye, face, respiratory, hearing and body protection.

Caution: Hand, wrist and arm injury may result from repetitive work, motion and overexposure to vibration.

Warning: Be sure that any loose clothing, hair and all jewelry is properly restrained.

- Secure inlet bushing on air tool with a wrench before attempting to install or remove the air fitting to avoid damaging housing assembly.
- Check tool RPM (speed) with tachometer with air pressure set at 90 PSIG while the tool is running. If tool is operating at a higher speed than the RPM marked on the tool housing, or operating improperly, the tool must be serviced and corrected before use.

Caution: Tool RPM must never exceed accessory RPM rating. Check accessory manufacturer for details on maximum operating speed or special mounting instructions.

- Before mounting an accessory regularly clean and inspect collet assembly parts for wear or damage. DO NOT use worn or damaged components.
- With power source disconnected from air tool, mount recommended accessory into collet assembly.
- The mandrel diameter of the accessory must insert freely, but not loosely, all the way to the base of the collet body before tightening the collet cap. Use wrenches provided.
- After accessory change or height adjustment, reposition the throttle lever to best protect operator from unintentional starts.
- When adjusting bases/guides make sure the collet nut and any other adjustment devices are securely tightened.
- Connect air tool to power source. Be careful NOT to depress throttle lever in the process. **Do not expose air tool to inlet pressure above 90 PSIG or (6.2 Bars).**

Caution: The mandrel shall be inserted to the full depth of the gripping jaws of the collet. At least one-half the mandrel length shall be inserted into the collet to prevent excessive overhang. Refer to accessory manufacturer's instructions for proper overhang. (Ref. ANSI B186.1)

Warning: Sliding the accessory's mandrel out from the collet insert creates an "OVER HANG" condition. This practice is NOT recommended, reducing the free speed of the tool by reducing the air pressure must be done to avoid cutting tool breakage and serious injury.

- When bits are fully inserted, a minimum of 1" in the collet, the remaining exposed shaft must NOT exceed 1/4".

CORRECT MANDREL MOUNTING

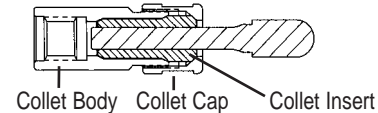

To install or remove the router bit: **Disconnect tool from air supply.**

- Use a 3/16" hex key to loosen the collar adapter screw. Remove the vacuum base.
- Use a 14 mm and a 19 mm open end wrench to install or remove the router bit.
- Install and secure the vacuum base.
- Adjust the router bit depth of cut.

Caution: After installing the accessory, before testing or use and/or after reassembling tool, the router must be started at a reduced speed to check for good balance. Gradually increase tool speed. DO NOT USE if tool vibration is excessive. Correct cause, and retest to insure safe operation.

- Keep hand and clothing away from working end of the air tool.
- Working end of tool has a potential of cutting and severing.
- Release throttle lever when air supply is interrupted.
- Make sure that work area is uncluttered, and visitors are at a safe range from the tools and debris.
- Use a vise or clamping device to hold work piece firmly in place.
- Tool is rear exhaust. Exhaust may contain lubricants, vane material, bearing grease and other materials flushed through tool.
- When routing end grain the router bit can grab the work piece, causing the operator to lose control. Use jigs whenever possible.
- Kickback may occur when operating the router at slow speeds. Make sure the work piece is secure.
- Hold the router firmly with both hands. The reaction torque of the motor can cause the tool to twist.
- Always make sure the work surface is free from foreign objects. Cutting into a dissimilar material can cause the bit and the tool to jump and damage the bit.
- Never start the tool when the bit is touching the workpiece. The bit may grab the workpiece and cause loss of control.
- Always feed the bit into the workpiece in the same direction as the bit rotation.
- Feeding the tool in the wrong direction causes the cutting edge of the bit to climb out of the work piece and pull the tool toward the operator.
- DO NOT force the power tool. Use the tool at its designed speed. Guide in a smooth constant motion.
- DO NOT let the airline impede operating motion.

Warning: Grinding certain materials can create explosive dust. It is the employers responsibility to notify the user of acceptable dust levels.

- Grinding can cause sparks which can cause fires or explosions. It is the users responsibility to make sure the work area is free of flammable materials.
- Always use dust extraction or suppression systems and personal protective equipment which are suitable for the materials being processed.
- Always work with a firm footing, posture and proper lighting.
- Turn off router after cut has been completed, be cautious of run down time of accessory.

Report to your supervisor any condition of the tool, accessories, or operation you consider unsafe.

Air System

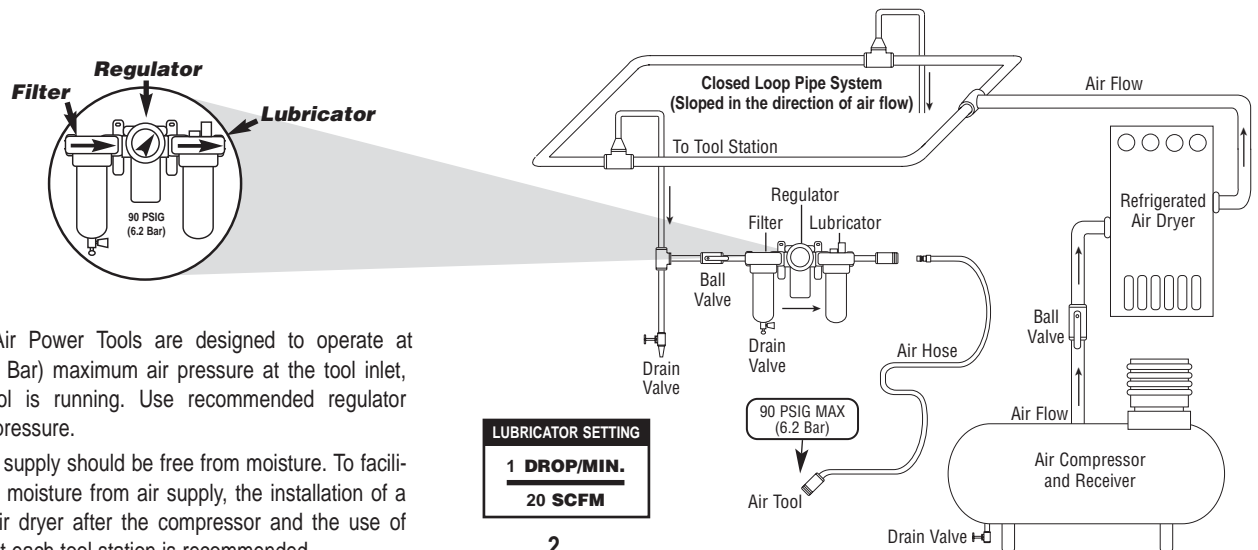

- Dynabrade Air Power Tools are designed to operate at 90 PSIG (6.2 Bar) maximum air pressure at the tool inlet, when the tool is running. Use recommended regulator to control air pressure.
- Ideally the air supply should be free from moisture. To facilitate removing moisture from air supply, the installation of a refrigerated air dryer after the compressor and the use of drain valves at each tool station is recommended.

Maintenance Instructions

Important: To keep tool safe a Preventative Maintenance Program is recommended whenever portable power tools are used. The program should include inspection of air supply lines, air line pressure, proper lubrication and repair of tools. Refer to ANSI B186.1 for additional maintenance information.

- Use only genuine Dynabrade replacement parts to ensure quality. To order replacement parts, specify **Model#**, **Serial#** and **RPM** of your air tool.
- It is strongly recommended that all Dynabrade rotary vane air tools be used with a Filter-Regulator-Lubricator to minimize the possibility of misuse due to unclean air, wet air or insufficient lubrication. Dynabrade recommends the following: **10681** Air Line Filter-Regulator-Lubricator — Provides accurate air pressure regulation, two-stage filtration of water contaminants and micro-mist lubrication of pneumatic components. Delivers up to 55 SCFM/1,558 LPM @ 145 PSIG/9.7 Bar (Max. Air Temperature of 140°F/60° C) **Note:** Two (2) 3/8" NPT Reducer Bushings are included.
- Dynabrade recommends one drop of air lube per minute for each 20 SCFM (example: if the tool specification states 40 SCFM, set the drip rate on the filter-lubricator to 2 drops per minute). Dynabrade Air Lube (P/N **95842**: 1 pt 473 ml) is recommended.

Routine Preventative Maintenance:

- Check free speed of tool regularly using a tachometer without the accessory mounted. After all tool repairs and whenever a router is issued for use, check tool RPM (speed) with tachometer with air pressure set at 90 PSIG while the tool is running. If tool is operating at a higher speed than the RPM marked on the tool housing, operating improperly or demonstrates unusual vibration, the tool must be serviced and corrected before use.
- Inspect accessories before mounting. Do not mount accessories that are damaged or nicked.
- Check accessory - speed rating. Rating on accessory must be greater than the tool speed marked on the housing.
- If accessory breakage occurs, investigate to determine the cause and correct before issuing tool for work.
- Mineral spirits are recommended when cleaning the tool and parts. Do not clean tool or parts with any solvents or oils containing acids, esters, ketones, chlorinated hydrocarbons or nitro carbons.
- **DO NOT** clean or maintain tools with chemicals that have a low flash point (example: WD-40®).
- A Motor Tune-Up Kit (P/N **96529**) is available which includes high wear and medium wear motor parts.
- Air tool markings must be kept legible at all times, if not, reorder housing and replace. User is responsible for maintaining specification information i.e.: Model #, S/N, and RPM. (See Assembly Breakdown)
- Blow air supply hose out prior to initial use.
- Visually inspect air hoses and fittings for frays, visible damage and signs of deterioration. Replace damaged or worn components.
- Refer to Dynabrade's Warning/Safety Operating Instructions Tag (Reorder No. **95903**) for safety information.

After maintenance is performed on tool, add a few drops of Dynabrade Air Lube (P/N **95842**) to the air line and start the tool a few times to lubricate air motor. Check for tool vibration before mounting accessory.

Handling and Storage:

- Use of tool rests, hangers and/or balancers is recommended.
- Protect tool inlet from debris, see Notice below.
- **DO NOT** carry tool by air hose or near the tool throttle lever.
- Protect tool from exposure to water, solvents, high humidity, freezing temperature and extreme temperature changes.
- **DO NOT USE** accessories that have been dropped or show signs of cracks, nicks or other defects.
- Store accessories in protective racks or compartments to prevent damage.

Machine Specifications

Model Number	Motor hp (W)	Motor RPM	Air Inlet Thread	Sound Level	Air Flow Rate SCFM (LPM)	Air Pressure PSIG (Bars)	Collet Size	Weight Pound (kg)	Length Inch (mm)	Height Inch (mm)
51332	.7 (522)	20,000	1/4" NPT	79 dB(A)	33 (935)	90 (6.2)	1/4 in.	2.6 (1.2)	11 (282)	3-1/2 (89)
51333	.7 (522)	20,000	1/4" NPT	79 dB(A)	33 (935)	90 (6.2)	1/4 in.	3.3 (1.5)	11 (282)	4 (102)

Additional Specifications: Air Inlet Thread 1/4" NPT • Hose I.D. 3/8" (10mm)

Sound Level is the pressure measurement according to the method outlined in ISO regulation ISO-15744.

Notice

All Dynabrade motors use the highest quality parts and metals available and are machined to exacting tolerances. The failure of quality pneumatic motors can most often be traced to an unclean air supply or the lack of lubrication. Air pressure easily forces dirt or water contained in the air supply into motor bearings causing early failure. Dirt often scores the cylinder walls and the rotor blades resulting in limited efficiency and power. Our warranty obligation is contingent upon proper use of our tools and cannot apply to equipment which has been subjected to misuse such as unclean air, wet air or a lack of lubrication during the use of this tool.

Lifetime Warranty

All Dynabrade portable pneumatic power tools are rigorously inspected and performance tested in our factory before shipping to our customers. If a Dynabrade tool develops a performance problem and an inherent defect is found during normal use and service, Dynabrade will warrant this tool against defects in workmanship and materials for the lifetime of the tool. Upon examination and review at our factory, Dynabrade shall confirm that the tool qualifies for warranty status, and will repair or replace the tool at no charge to the customer. Normally wearable parts and products are NOT covered under this warranty. Uncovered items include bearings, contact wheels, rotor blades, regulators, valve stems, levers, shrouds, guards, O-rings, seals, gaskets and other wearable parts. Dynabrade's warranty policy is contingent upon proper use of our tools in accordance with factory recommendations, instructions and safety practices. It shall not apply to equipment that has been subjected to misuse, negligence, accident or tampering in any way so as to affect its normal performance. To activate lifetime warranty, customer must register each tool at www.dynabrade.com. Dynabrade will not honor lifetime warranty on unregistered tools. A one-year warranty will be honored on all unregistered portable pneumatic power tools. Lifetime warranty applies only to portable pneumatic tools manufactured by Dynabrade, Inc. in the USA. Lifetime warranty applies only to the original tool owner; warranty is non-transferable.

.7hp Vacuum Router

Complete Assembly Breakdown

Index Key

No.	Part #	Description
1	96272	Screw (3)
2	25331	Plate - 4in.
3	08505	Shroud Assembly
4	27331	Spacer (2)
5	97111	Set Screw (2)
6	31643	Knob (2)
7	25831	Lock Nut
8	08504	Port Extension
9	95247	Screw
10	26330	Collar Adapter
11	97598	Knob (2)
12	26833	Thumb Screw
13	26830	Roller Guide
14	11016	Bearing
15	95128	Screw
16	26831	Roller Bracket
17	97325	Lock Washer (2)
18	96272	Screw (2)
19	26832	Mounting Block
20	25330	Plate - 3-1/2in.
21	08503	Shroud Assembly
22	50012	Collet Cap
23	50013	1/4" Collet Insert
24	50011	Collet Body
25	50010	1/4" Collet Assy.
26	25830	Lock Ring Cover
27	53175	Collar
28	27330	Spacer
29	01708	Rotor Nut
30	01007	Bearing
31	01121	Shim Pack (3/pkg.)
32	01008	Bearing Plate
33	50767	Pin (2)
34	01010	Rotor Spacer
35	55025	Rotor
36	01185	Blade (4/pkg.)
37	01028	Cylinder
38	01721	Bearing Plate
39	02649	Bearing
40	01089	Safety Lock Lever
41	01477	Valve Stem
42	95558	Retainer Ring
43	51338	Housing - 51332
44	95730	O-Ring
45	01024	O-Ring
46	01247	Speed Reg. Assy.
47	01017	Pin
48	01464	Seal
49	01472	Tip Valve
50	01468	Spring
51	01564	Air Control Ring
52	95711	Retaining Ring
53	95438	O-Ring
54	94521	Muffler Base
55	94524	Sintered Muffler
56	94525	Felt Muffler
57	94522	Muffler Cap
58	95375	O-Ring
59	94526	Spacer
60	94523	Inlet Adapter
61	94300	1/4" Swivel
62	94520	Muffler Assembly

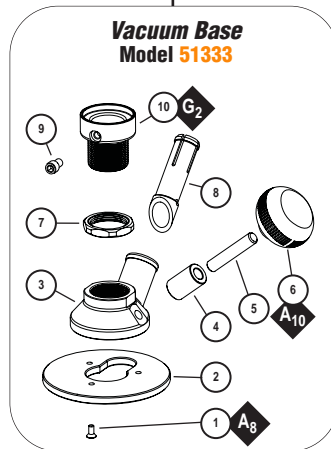
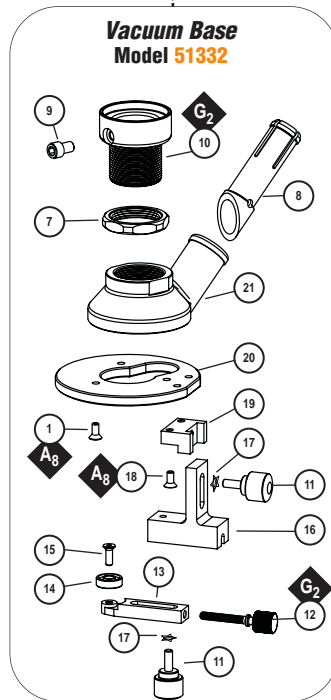

95262 - 14 mm
95281 - 19 mm

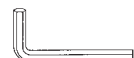

95049 - 3/16 in.

Please indicate:
Model #, Serial #, and RPM
when ordering replacement parts.

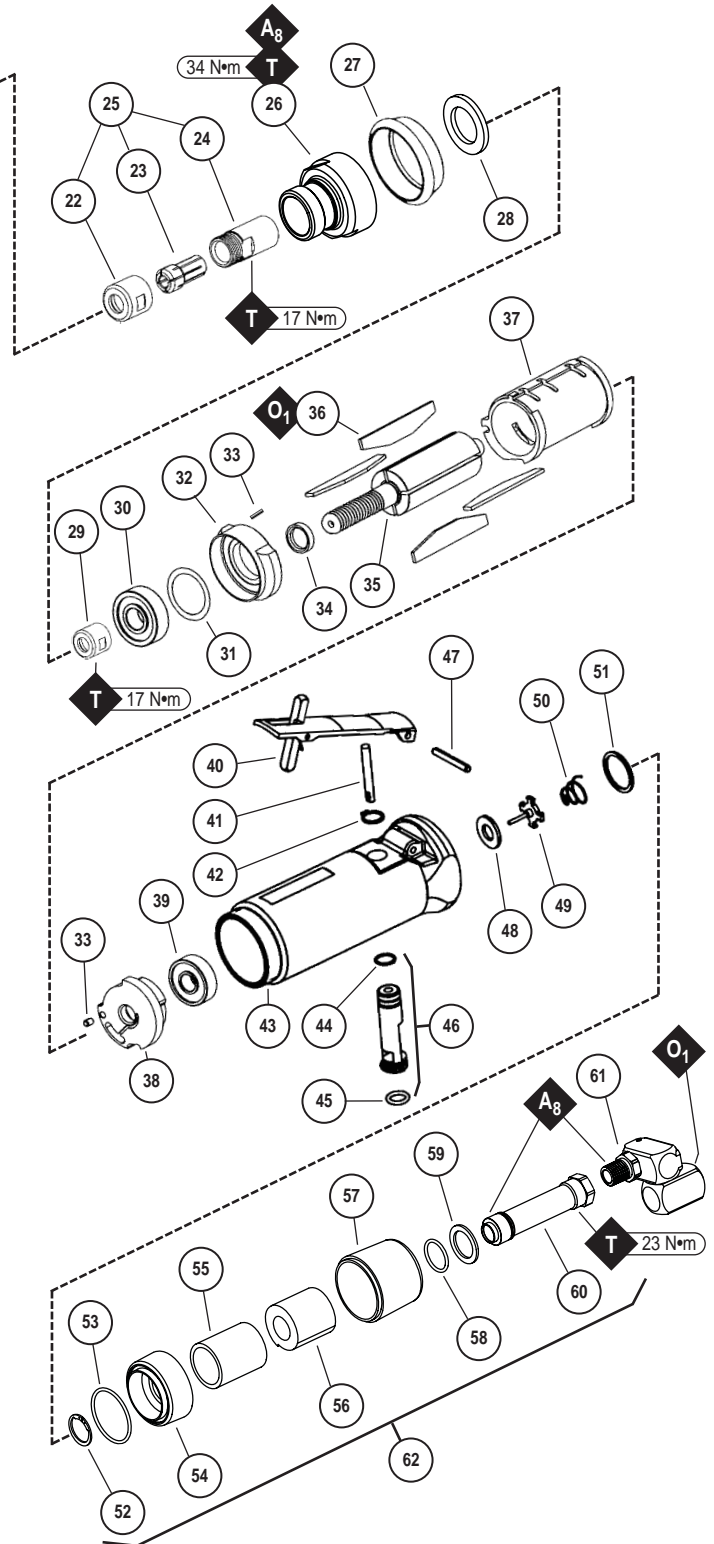

KEY	
O	Oil: O ₁ = Air Lube
A	Adhesive: A ₈ = Loctite #567 A ₁₀ = Loctite #243
T	Torque: N*m x 8.85 = In. - lbs.
G	Grease: G ₁ = Lubriplate 630 AA G ₂ = Loctite #771

Disassembly Instructions - .7hp Vacuum Router

Important: The Dynabrade Pneumatic Power Tool Lifetime Warranty Policy does NOT cover normally wearable parts and products. Before servicing this tool please contact Dynabrade Inc. or a Dynabrade Subsidiary for information regarding the Dynabrade Pneumatic Power Tool Lifetime Warranty Policy.

Notice: Special repair tooling referred to in these instructions can be ordered from Dynabrade. (See Page 8)

Disconnect tool from power source before tool repair.

Remove the Air Motor from the Vacuum Base Shroud Assembly:

1. Loosen and remove the collet; cap, insert, and accessory.
2. Use the **95049** Hex Key (3/16") to loosen the **95247** Screw and remove the **26330** Collar Adapter from the **25830** Lock Ring Cover.

Motor Disassembly:

1. Secure the flats of the motor housing in a vise with aluminum or bronze jaws.
2. Remove the **25830** Lock Ring Cover with an adjustable wrench. Turn it counterclockwise. Remove the **27330** Spacer.
3. Pull the motor assembly out of the housing.
4. Fasten the **96346** Bearing Separator (2") around the portion of the **01028** Cylinder that is nearest the **01721** Rear Plate.
5. Position the bearing separator on the table of the **96232** Arbor Press (#2) with the collet body end of the air motor pointing down.
6. Use a 1/4" (6 mm) dia. flat end drive punch to push the rotor shaft out of the **02649** Bearing. Remove the **01185** Vanes.
7. Use the **96213** Bearing Removal Tool and the arbor press to remove the **02649** Bearing from the rear plate.
8. Secure the vane portion of the **55021** Rotor in a vise with aluminum or bronze jaws.
9. Use an adjustable wrench or the **95262** Wrench (14 mm) to remove the collet body. Turn it counterclockwise.
10. Remove the **01008** Front Plate, **01007** Bearing, Shims, and **01010** Spacer.

Motor Disassembly Complete.

94520 Muffler and Valve Body Disassembly:

1. Secure the flats of the motor housing in a vise with aluminum or bronze jaws with the **94520** Muffler Assembly pointing up.
2. Remove the **94300** Dynaswivel. Turn it counterclockwise.
3. Use an 11/16" socket wrench to remove the **94523** Inlet Adapter. Turn it counterclockwise.
4. Remove the valve components.
5. Use a 2.5 mm drive punch to remove the **01017** Pin and throttle lever.
6. Refer to the exploded view of the muffler for component identification and order of disassembly.

94520 Muffler and Valve Body Disassembly Complete.

Important: Clean and inspect all parts before assembling.

Motor Assembly:

1. Secure the vane portion of the **55021** Rotor in a vise with aluminum or bronze jaws.
2. Install the **01010** Spacer onto the rotor.
3. Place .003" (.08 mm) shim thickness into the **01008** Front Plate and install the **01007** Bearing. Slide this assembly onto the rotor.
4. Install the collet body onto the rotor. Turn it clockwise. (Torque to 17 N•m/150 in. lbs.)
5. Check the clearance between the rotor and the bearing plate with a .001" (.03 mm) thick feeler gauge. The clearance should be .001" (.03 mm) to .0015" (.04 mm). If it is necessary to adjust the clearance, repeat steps 3-5, adding or removing shims. Once the proper clearance is achieved, proceed with the motor assembly.
6. Install the **01185** Vanes (4/pkg.) that have been lubricated with the **95842** Dynabrade Air Lube 10W/NR (or equivalent).
7. Use the **96240** Bearing Press Tool to install the **02649** Bearing into the **01721** Rear Plate. **Note:** Use the **96240** Bearing Press Tool so that it touches against the outside race of the bearing.
8. Place the **01028** Cylinder onto the rotor assembly with the air inlet passage aligned with the air inlet passage in the **01721** Rear Plate.
9. Use the **96240** Bearing Press Tool and the arbor press to install the bearing/rear plate assembly onto the **55021** Rotor. **Note:** The press tool should push against the inside race of the bearing. **Important:** Carefully press the bearing/rear plate assembly onto the rotor to achieve a snug fit between the bearing plates and the cylinder. A snug fit will trap the cylinder while still allowing it to be shifted from side to side with a slight amount of finger pressure. A loose fit will not achieve proper preload of the motor bearings.
10. Align the outside diameters of the front plate, cylinder, and rear plate. Also, align the air inlet passage in the rear plate with the air inlet on the inside of the motor housing. Make sure that the motor is positioned properly so that it fits all the way into the housing before installing the lock ring. Carefully slide the motor assembly into the housing.
11. Secure the flats of the motor housing in a vise with aluminum or bronze jaws with the collet body pointing up.
12. Install the **27330** Spacer.
13. Apply a small amount of the Loctite® #567 (or equivalent) to the threads of the **25830** Lock Ring Cover. Install the lock ring cover onto the motor housing. Turn it clockwise. (Torque to 34 N•m/300 in. lbs.)

(continued on next page)

Assembly Instructions - .7hp Vacuum Router (Continued)

Motor Assembly:

14. Check the motor for proper adjustment. - With the motor housing mounted in the vise, pull up on the end of the collet body while turning it back and forth. Note: Apply 7-10 lbf. (31-44 N). Perform the same procedure pushing down on the collet body with the same amount of force. The rotor should turn freely without any drag or rub. If a pull rub is detected, increase preload or remove shims. If a push rub is detected, remove some of load or add shims.
15. Install the collet insert and cap.
16. Install the **26330** Collar Adapter onto the **25830** Lock Ring Cover. Note: Orient the vacuum port on the vacuum base shroud assembly so that it is in the same position as the **01089** Safety Lock Throttle Lever.
17. Use the **95049** Hex Key (3/16") to secure the **95247** Screw.

Motor Assembly Complete.

94520 Muffler and Valve Body Assembly:

1. Refer to the exploded view of the muffler for component identification and the order of assembly. Note: Completely assemble the **94520** Muffler.
2. Secure the flats of the motor housing in a vise with aluminum or bronze jaws with the air inlet opening pointing up.
3. Install the **01464** Seal into the air inlet opening in the motor housing.
4. Install end of the **01477** Valve Stem with the hole, into the **01247** Speed Regulator.
5. Align the hole in the **01477** Valve Stem with the air inlet opening in the motor housing.
6. Use needle nose pliers to grasp the white plastic end of the **01472** Tip Valve and insert the metal pin of the tip valve into the hole in the valve stem.
7. Install the small end of the **01468** Conical Spring against the back of the tip valve.
8. Apply a small amount of the Loctite® #567 (or equivalent) to the threads of the **94523** Inlet Adapter.
9. Use an 11/16" socket wrench to install the **94523** Inlet Adapter. Turn it clockwise. (Torque to 23 N•m/200 in. lbs.)
10. Install the **01089** Safety Lock Throttle Lever securing it with the **01017** Pin.
11. Use an 11/16" open-end wrench to hold the **94523** Inlet Adapter stationary when installing the **94300** Dynaswivel. Turn it clockwise.

Tool Assembly Complete. Please allow 30 minutes for adhesives to cure before operating tool.

Important: Before operating, place 2-3 drops of Dynabrade Air Lube (P/N **95842**) directly into inlet with throttle lever depressed. Operate tool for 30 seconds to allow air lube to properly lubricate internal motor components. Motor should now be tested for proper operation at 90 PSIG max. If tool operates at a higher RPM than marked on the tool or if vibration and sound levels seem abnormal, the tool should be serviced to correct the cause before use.

Loctite® is a registered trademark of Loctite Corp.

Instructions for height adjustment of base:

1. Disconnect tool from air supply.
2. Loosen **25831** Lock Nut.
3. Adjust height by turning the motor until cutter is in desired location.
4. Tighten **25831** Lock Nut.

Height Adjustment Complete.

To adjust vacuum base roller guide:

1. Disconnect tool from air supply.
2. Loosen side knob to change vertical location of roller guide.
3. Loosen bottom knob and use thumb screw to change horizontal location of roller guide.
4. Tighten the side and bottom knobs to secure the roller guide in desired location.

Vacuum Base Roller Guide Adjustment Complete.

To install or remove the vacuum port extension tube:

1. Disconnect tool from air supply.
2. Use a 3/16" hex key to loosen the collar adapter screw. Remove the vacuum base.
3. Insert the slotted end of the tube into the vacuum base. Rotate the tube to clear the router bit cutting area. Position the tube angle 90° to the vacuum base plate. Note: When installing the tube into the vacuum base with roller guide, loosen side knob and remove the roller guide.
4. Compress and push on the slotted end of the tube to remove it from the vacuum base.
5. Install and secure the vacuum base.
6. Adjust the router bit depth of cut, and roller guide if necessary.

Vacuum Port Extension Tube (install/remove) Complete.

Preventative Maintenance Schedule

For All .7hp Vacuum Routers

This service chart is published as a guide to expectant life of component parts. The replacement levels are based on average tool usage over one year. Dynabrade Inc. considers one year usage to be 1,000 hours or 50% of a man year. Parts included in motor tune-up kit are identified by High Wear and Medium Wear items.

LEGEND

X	Type of wear, no other comments apply.
L	Easily lost. Care during assembly/disassembly.
D	Easily damaged during assembly/disassembly.



96529 – Motor Tune-Up Kit

Index #	Part Number	Description	Number Required	High Wear 100%	Medium Wear 70%	Low Wear 30%	Non-Wear 10%
1	96272	Screw	3				L
2	25331	Plate - 4in.	1			X	
3	08505	Shroud Assembly	1				X
4	27331	Spacer	2				X
5	97111	Set Screw	2				X
6	31643	Knob	2				X
7	25831	Lock Nut	1				X
8	08504	Port Extension	1			X	
9	95247	Screw	1				X
10	26330	Collar Adapter	1				X
11	97598	Knob	1				L
12	26833	Thumb Screw	1				L
13	26830	Roller Guide	1				X
14	11016	Bearing	1			X	
15	95128	Screw	1				X
16	26831	Roller Bracket	1				X
17	97325	Lock Washer	2				L
18	96272	Screw	2				L
19	26832	Mounting Block	1				X
20	25330	Plate - 3-1/2in.	1			X	
21	08503	Shroud Assembly	1				X
22	50012	Collet Cap	1			X	
23	50013	1/4" Collet Insert	1			X	
24	50011	Collet Body	1				X
25	50010	1/4" Collet Assy.	1			X	
26	25830	Lock Ring Cover	1				X
27	53175	Collar	1				X
28	27330	Spacer	1				X
29	01708	Rotor Nut	1				X
30	01007	Bearing	1		T		
31	01121	Shim Pack (3/pkg.)	1	T			
32	01008	Bearing Plate	1			X	
33	50767	Pin	2			X	
34	01010	Rotor Spacer	1			X	
35	55025	Rotor	1				X
36	01185	Blade (4/pkg.)	1	T			
37	01028	Cylinder	1			X	
38	01721	Bearing Plate	1			X	
39	02649	Bearing	1		T		
40	01089	Safety Lock Lever	1			X	
41	01477	Valve Stem	1		T		
42	95558	Retainer Ring	1			T	
43	See Note	Housing	1				X
44	95730	O-Ring	1			X	
45	01024	O-Ring	1			X	
46	01247	Speed Reg. Assy.	1			T	
47	01017	Pin	1		T		
48	01464	Seal	1			T	
49	01472	Tip Valve	1			T	
50	01468	Spring	1		T		
51	01564	Air Control Ring	1			X	
52	95711	Retaining Ring	1			T	
53	95438	O-Ring	1			T	
54	94521	Muffler Base	1			X	
55	94524	Sintered Muffler	1	T			
56	94525	Felt Muffler	1	T			
57	94522	Muffler Cap	1			X	
58	95375	O-Ring	1			T	
59	94526	Spacer	1				X
60	94523	Inlet Adapter	1			X	
61	94300	1/4" Swivel	1			X	
62	94520	Muffler Assembly	1			X	

Note: Please refer to page 4 of tool manual for specific part number.

Optional Accessories



96529 Motor Tune-Up Kit

- Includes assorted parts to help maintain and repair motor.

01713 Drop-In Motor



Dynabrade Air Lube

- Formulated for pneumatic equipment.
- Absorbs up to 10% of its weight in water.
- Prevents rust and formation of sludge.
- Keeps pneumatic tools operating longer with greater power and less down time.

95821: 4 oz. (108 ml)

95842: 1 pt. (473 ml)

95843: 1 gal. (3.8 L)



Portable Vacuum Systems

- Dynabrade offers a wide assortment of vacuuming options to choose from. To help make your selection please request the most current portable vacuum systems literature from your local representative or by searching our web site.



Composite-Style Coupler and Plug Assemblies

- Easy connect/disconnect by single push-button action.
- Lightweight 1.4 oz. (.05 Kg), non-marring composite material.

94990 - 1/4" Female NPT coupler with 1/4" Male Plug.



Coupler and Plug Assemblies

- Durable metal construction.

95676 - 1/4" Female NPT coupler with 1/4" Male Plug.



Open-End Wrench

11278 - 1-1/2 in. open-end.

Special Repair Tooling:

96346 Bearing Separator (2")

96232 Arbor Press (#2)

96213 Bearing Removal Tool

96240 Bearing Press Tool

Reference Contact Information

1. **American National Standards Institute – ANSI**
25 West 43rd Street
Forth Floor
New York, NY 10036
Tel: 1 (212) 642-4900
Fax: 1 (212) 398-0023
2. **Government Printing Office – GPO**
Superintendent of Documents
Attn. New Orders
P.O. Box 371954
Pittsburgh, PA 15250-7954
Tel: 1 (202) 512-1803
3. **European Committee for Standardization**
Rue de Stassart 36
B - 1050 Brussels, Belgium

Visit Our Web Site: www.dynabrade.com

Email: Customer.Service@Dynabrade.com



DYNABRADE, INC., 8989 Sheridan Drive • Clarence, NY 14031-1419 • Phone: (716) 631-0100 • Fax: 716-631-2073 • International Fax: 716-631-2524
DYNABRADE EUROPE S.à.r.l., Zone Artisanale • L-5485 Wormeldange—Haut, Luxembourg • Telephone: 352 76 84 94 1 • Fax: 352 76 84 95 1

© DYNABRADE, INC., 2009

PRINTED IN USA