

3" Right Angle Grinder

Air Tool Manual – Safety, Operation and Maintenance

SAVE THIS DOCUMENT, EDUCATE ALL PERSONNEL

Model:

52705 – 15,000 RPM
Accepts: 3" (80mm) Type 27 Grinding Wheels
with 3/8" Arbor Hole



FIND THE MOST CURRENT OFFERING OF SUPPORT DOCUMENTS AND ACCESSORIES @ WWW.DYNABRADE.COM

⚠ WARNING

Read and understand this tool manual before operating your air tool. Follow all safety rules for the protection of operating personnel as well as adjacent areas. Always operate, inspect and maintain this tool in accordance with the American National Safety Institute (ANSI) Safety Code for Portable Air Tools – B186.1. For additional safety information, refer to Safety Requirements for the Use, Care and Protection of Abrasive Wheels – ANSI B7.1, Code of Federal Regulation – CFR 29 Part 1910, European Committee for Standards (EN) Hand Held Non-Electric Power Tools – Safety Requirements and applicable State and Local Regulations.

SAFETY LEGEND

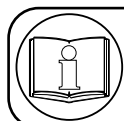

⚠ WARNING

Read and understand tool manual before work starts to reduce risk of injury to operator, visitors, and tool.

⚠ WARNING

Practice safety requirements. Work alert, have proper attire, and do not operate tools under the influence of alcohol or drugs.



⚠ WARNING

Eye protection must be worn at all times, eye protection to conform to ANSI Z87.1.

⚠ WARNING

Ear protection to be worn when exposure to sound, exceeds the limits of applicable Federal, State or local statutes, ordinances and/or regulations.



⚠ WARNING

Respiratory protection to be used when exposed to contaminants that exceed the applicable threshold limit values required by law.

⚠ WARNING

Air line hazard, pressurized supply lines and flexible hoses can cause serious injury. Do not use damaged, frayed or deteriorated air hoses and fittings.



⚠ WARNING

Some dust created by grinding, sanding, drilling, and other construction activities contain chemicals known to cause cancer, birth defects or other reproductive harm. Some examples of these chemicals are:

- Lead from lead-based paints
- Crystalline silica from bricks and cement and other masonry products
- Arsenic and chromium from chemically treated lumber

Your risk from these exposures varies, depending on how often you do this type of work. To reduce your exposure to these chemicals: work in a well ventilated area, and work with approved safety equipment, such as those dust masks that are specially designed to filter out microscopic particles.

SAFETY INSTRUCTIONS

Carefully Read all instructions before operating or servicing any Dynabrade® Abrasive Power Tool.

Products offered by Dynabrade are not to be modified, converted or otherwise altered from the original design without expressed written consent from Dynabrade, Inc.

Tool Intent: 3" Right Angle Grinders are ideal for removal of material using Type 27 grinding wheels.

Do Not Use Tool For Anything Other Than Its Intended Applications.

This power tool is not intended for use in potentially explosive atmospheres and is not insulated against contact with electrical power.

Training: Proper care, maintenance, and storage of your air tools will maximize their performance.

- Employer's Responsibility – Provide 3" Right Angle Grinder operators with safety instructions and training for safe use of tools and accessories.

Accessory Selection:

- Use only Type 27 grinding wheels with 3/8" arbor hole.
- Abrasive/accessory RPM (speed) rating MUST be approved for AT LEAST the tool RPM rating.
- Before mounting an accessory, visually inspect for defects. Do not use defective accessories.
- Use only recommended accessories. Reference Dynabrade catalog and this tool manual.
- Follow tool specifications before choosing size and type of accessory.
- Only use recommended fittings and air line sizes. Air supply hoses and air hose accessories must have a minimum working pressure of 150 PSIG (10 Bars, g) or 150 percent of the maximum pressure produced in the system, whichever is higher. (See tool Machine Specifications table.)

OPERATING INSTRUCTIONS

Warning: Always wear eye protection. Operator of tool is responsible for following: accepted eye, face, respiratory, hearing and body protection. Always use wheel guard. Make sure it is positioned to best protect the operator and make sure it is securely fastened. Wheel guards that are worn, damaged or have been subject to a wheel breaking must be replaced.

Caution: Hand, wrist and arm injury may result from repetitive work, motion and overexposure to vibration.

- Keep hand and clothing away from working end of the air tool.

Operation: Be sure that any loose clothing, hair and all jewelry is properly restrained.

- Secure inlet bushing on air tool with a wrench before attempting to install the air fitting to avoid damaging housing assembly.
- BEFORE MOUNTING A WHEEL, after all tool repairs and whenever a grinder is issued for use, check tool RPM (speed) with tachometer with air pressure set at 90 PSIG while the tool is running. If tool is operating at a higher speed than the RPM marked on the tool housing, or operating improperly, the tool must be serviced and corrected before use.

Caution: Wheel speed rating must be approved for at least the tool RPM rating. Check accessory manufacturer for details on maximum operating speed or special mounting instructions.

TYPE 27 Grinding Wheel Mounting

- With power source disconnected from the air tool.
- Clean spindle and flange mounting surfaces. Inspect for nicks, cuts and sharp edges.
- Install drive flange as shown in diagram onto Model 52705.
- Check for flange flatness and runout by rotating spindle and drive flange together.
- Inspect Type 27 grinding wheels for cracks and or defects before mounting.
- Install Type 27 grinding wheel as shown in diagram.
- Install outer flange nut as shown in diagram and secure flange firmly against the wheel.
- Check for wheel firmness by holding the spindle and pulling on the edge of the wheel in the tightening direction.

Caution: Over tightening the outer flange nut can cause damage to the wheel and/or flanges.

- Use only Dynabrade flanges: Model 52705: 50093 Back-Up Flange, 50091 Flange

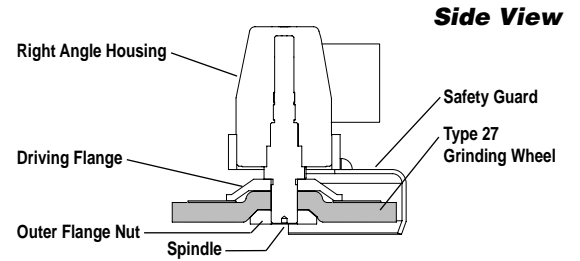

- Connect air tool to power source. Be careful NOT to depress throttle lever in the process. Do not expose air tool to inlet pressure above 90 PSIG or (6.2 Bars).

Caution: After installing the accessory, make sure that no one is in the unguarded plane of the wheel before starting the grinder. IN A PROTECTED AREA, test run the wheel at a reduced speed to check for good balance. Gradually increase tool speed. DO NOT USE if tool vibration is excessive. Correct cause, and retest to insure safe operation. Test wheel at its free speed (RPM) in a protected area for at least one minute before applying the wheel to the work.

- Make sure that work area is uncluttered, and visitors are at a safe range from the tools and debris.
- Air tools are not intended for use in explosive atmospheres and are not insulated for contact with electric power sources.
- Use a vise or clamping device to hold work piece firmly in place.
- Do not apply excessive force on tool or apply "rough" treatment to it.
- Always work with a firm footing, posture and proper lighting.
- Ensure that sparks and debris resulting from work does not create a hazard.
- This tool has rear exhaust. Exhaust may contain lubricants, vane material, bearing grease, and other materials flushed thru the tool.

Warning: Grinding certain materials can create explosive dust. It is the employers responsibility to notify the user of acceptable dust levels.

- Grinding can cause sparks which can cause fires or explosions. It is the users responsibility to make sure the work area is free of flammable materials.

Report to your supervisor any condition of the tool, accessories, or operation you consider unsafe.

Air System

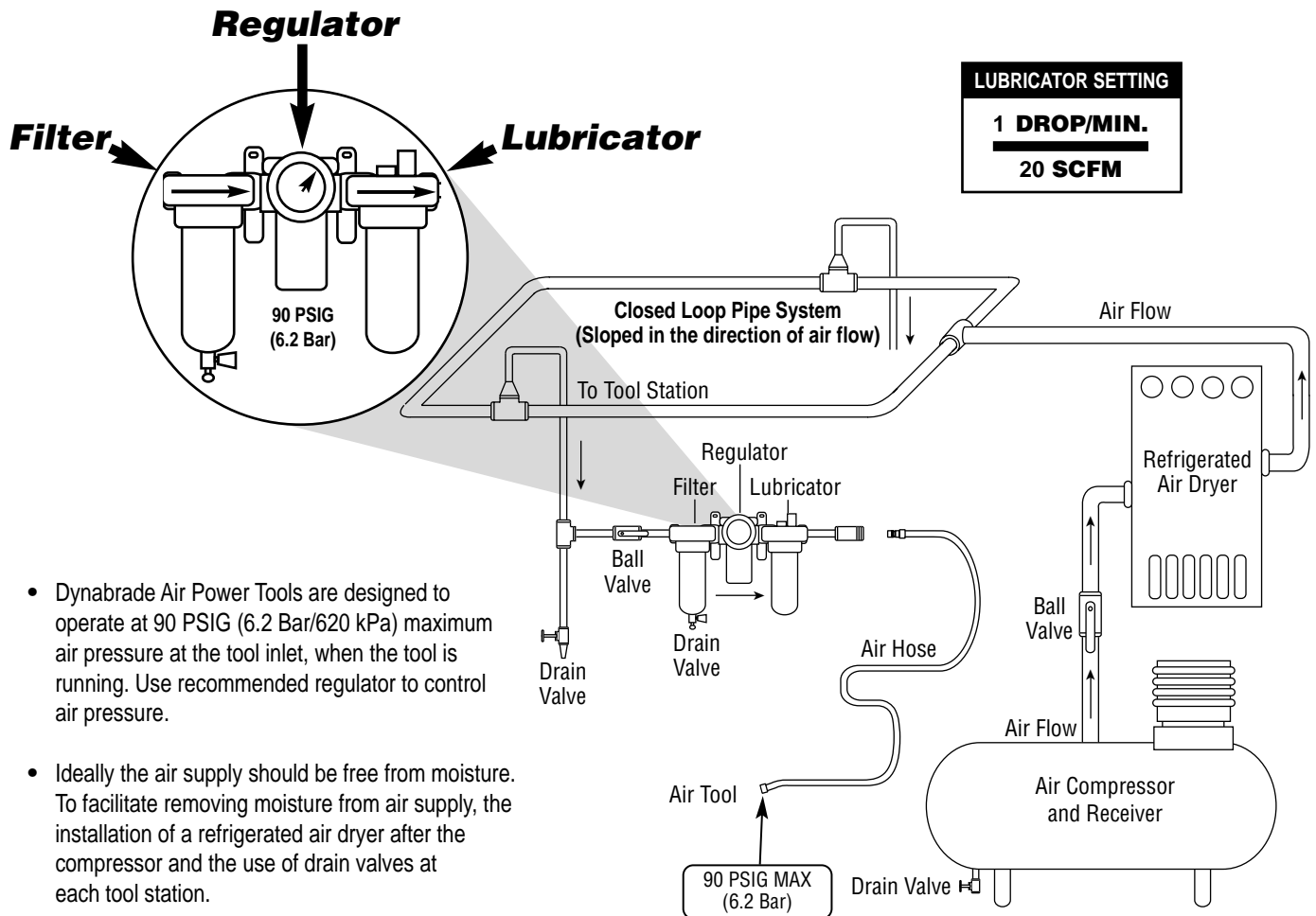

- Dynabrade Air Power Tools are designed to operate at 90 PSIG (6.2 Bar/620 kPa) maximum air pressure at the tool inlet, when the tool is running. Use recommended regulator to control air pressure.
- Ideally the air supply should be free from moisture. To facilitate removing moisture from air supply, the installation of a refrigerated air dryer after the compressor and the use of drain valves at each tool station.

Maintenance Instructions

Important: A Preventative Maintenance Program is recommended whenever portable power tools are used. The program should include inspection of air supply lines, air line pressure, proper lubrication and repair of tools. Refer to ANSI B186.1 for additional maintenance information.

- Use only genuine Dynabrade replacement parts to insure quality. To order replacement parts, specify **Model#**, **Serial#** and **RPM** of your air tool.
- It is strongly recommended that all Dynabrade rotary vane air tools be used with a Filter-Regulator-Lubricator to minimize the possibility of misuse due to unclean air, wet air or insufficient lubrication. Dynabrade recommends the following: **11405** Air Line Filter-Regulator-Lubricator — Provides accurate air pressure regulation, two-stage filtration of water contaminants and micro-mist lubrication of pneumatic components. Operates up to 40 SCFM @ 100 PSIG has 3/8" NPT female ports.
- **Lubricate wick system through the angle gear oil fitting with 2-3 plunges for every 24 hours of use, to achieve maximum gear life.**
Important: Use only the recommended angle gear oil for the wick system. Do not contaminate the wick with any other oil or grease product. (Order **95848** Gear Oil and **95541** Gun)
- Dynabrade recommends one drop of air lube per minute for each 20 SCFM (example: if the tool specification states 40 SCFM, set the drip rate on the filter-lubricator to 2 drops per minute). Dynabrade Air Lube (P/N **95842**: 1 pt 473 ml) is recommended.

Routine Preventative Maintenance:

- Check free speed of 3" Right Angle Grinder using a tachometer.
- Inspect flanges regularly for nicks, cuts, sharp edges, flatness and runout. Replace damaged or worn flanges with genuine Dynabrade flanges.
- Inspect wheel guard for wear or damage. Guards that are bent and severely worn or subject to a wheel breakage must be replaced.
- Inspect grinding wheels before mounting. Do not mount wheels that are damaged or cracked.
- Check grinding wheel - speed rating. Rating on wheel must be greater than the tool speed marked on the housing.
- If grinding wheel breakage occurs, investigate to determine the cause and correct before issuing tool for work.

- Mineral spirits are recommended when cleaning the tool and parts. Do not clean tool or parts with any solvents or oils containing acids, esters, ketones, chlorinated hydrocarbons or nitro carbons.
- DO NOT clean or maintain tools with chemicals that have a low flash point (example: WD-40®).
- A Motor Tune-Up Kit (P/N **96179**) is available which includes high wear and medium wear motor parts.
- Air tool labels must be kept legible at all times, if not, reorder label(s) and replace. User is responsible for maintaining specification information i.e.: Model #, S/N, and RPM. (See Assembly Breakdown)
- Blow air supply hose out prior to initial use.
- Visually inspect air hoses and fittings for frays, visible damage and signs of deterioration. Replace damaged or worn components.
- Refer to Dynabrade's Warning/Safety Operating Instructions Tag (Reorder No. **95903**) for safety information.

After maintenance is performed on tool, add a few drops of Dynabrade Air Lube (P/N **95842**) to the air line and start the tool a few times to lubricate air motor. Check for tool vibration before mounting abrasive wheel accessory.

Handling and Storage:

- Use of tool rests, hangers and/or balancers is recommended.
- Protect tool inlet from debris (see Notice below).
- DO NOT carry tool by air hose or near the tool throttle lever.
- Protect Type 27 depressed center wheel from exposure to water, solvents, high humidity, freezing temperature and extreme temperature changes.
- DO NOT USE Type 27 depressed center wheels that have been dropped or show signs of cracks, nicks or other defects.
- Store accessories in protective racks or compartments to prevent damage.

Machine Specifications

Model Number	Motor hp (W)	Motor RPM	Sound Level	Maximum Air Flow CFM/SCFM (LPM)	Spindle Thread	Air Pressure PSIG (Bars)	Weight Pound (kg)	Length Inch (mm)	Height Inch (mm)
52705	.4 (306)	15,000	80 dB(A)	3/24 (680)	3/8"-24 male	90 (6.2)	1.6 (.7)	7-1/2 (189)	3 (75)

Additional Specifications: Air Inlet Thread 1/4" NPT • Hose I.D. 1/4" or 8mm

Notice

All Dynabrade motors use the highest quality parts and metals available and are machined to exacting tolerances. The failure of quality pneumatic motors can most often be traced to an unclean air supply or the lack of lubrication. Air pressure easily forces dirt or water contained in the air supply into motor bearings causing early failure. It often scores the cylinder walls and the rotor blades resulting in limited efficiency and power. Our warranty obligation is contingent upon proper use of our tools and cannot apply to equipment which has been subjected to misuse such as unclean air, wet air or a lack of lubrication during the use of this tool.

One Year Warranty

Following the reasonable assumption that any inherent defect which might prevail in a product will become apparent to the user within one year from the date of purchase, all equipment of our manufacture is warranted against defects in workmanship and materials under normal use and service. We shall repair or replace at our factory, any equipment or part thereof which shall, within one year after delivery to the original purchaser, indicate upon our examination to have been defective. Our obligation is contingent upon proper use of Dynabrade tools in accordance with factory recommendations, instructions and safety practices. It shall not apply to equipment which has been subject to misuse, negligence, accident or tampering in any way so as to affect its normal performance. Normally wearable parts such as bearings, contact wheels, rotor blades, etc., are not covered under this warranty.

Right Angle Grinder Complete Assembly

Index Key

No.	Part #	Description
1	02059	3" Guard Assembly
2	50091	Flange
3	50093	Back-Up flange
4	02083	Spindle
5	02035	Lock Nut
6	01486	Felt Silencer
7	54520	Bearing
8	97116	Shim
9	97117	Shim
10	97118	Shim
11	02597	Gear
12	02044	Wick
13	02045	Wick
14	02031	Housing – Includes:
14A	01041	Gear Oil Fitting
14B	02041	Gear Oil Plate
14C	02033	Needle Bearing
15	02598	Pinion
16	01461	Lock Nut
17	02697	Bearing
18	54543	Shim
19	54544	Shim
20	54551	Shim
21	01478	Bearing Plate
22	50767	Pin (2)
23	01479	Spacer
24	02037	Rotor
25	01480	Blade (4/pkg.)
26	01476	Cylinder
27	02676	Bearing Plate
28	02696	Bearing
29	02679	Shield
30	01547	Collar
31	02058	Housing
32	12132	Pin
33	01449	Valve Stem
34	01462	Safety Throttle Lever
35	01464	Seal
36	01472	Tip Valve
37	01468	Spring
38	01564	Air Control Ring
39	95558	Retaining Ring
40	95730	O-Ring
41	01469	Speed Regulator Assy.
42	01024	O-Ring
43	95438	O-Ring
44	95711	Retaining Ring
45	94521	Muffler Base
46	94528	Felt Muffler
47	94522	Muffler Cap
48	95375	O-Ring
49	94526	Spacer
50	94523	Inlet Adapter
51	94519	Muffler Assembly

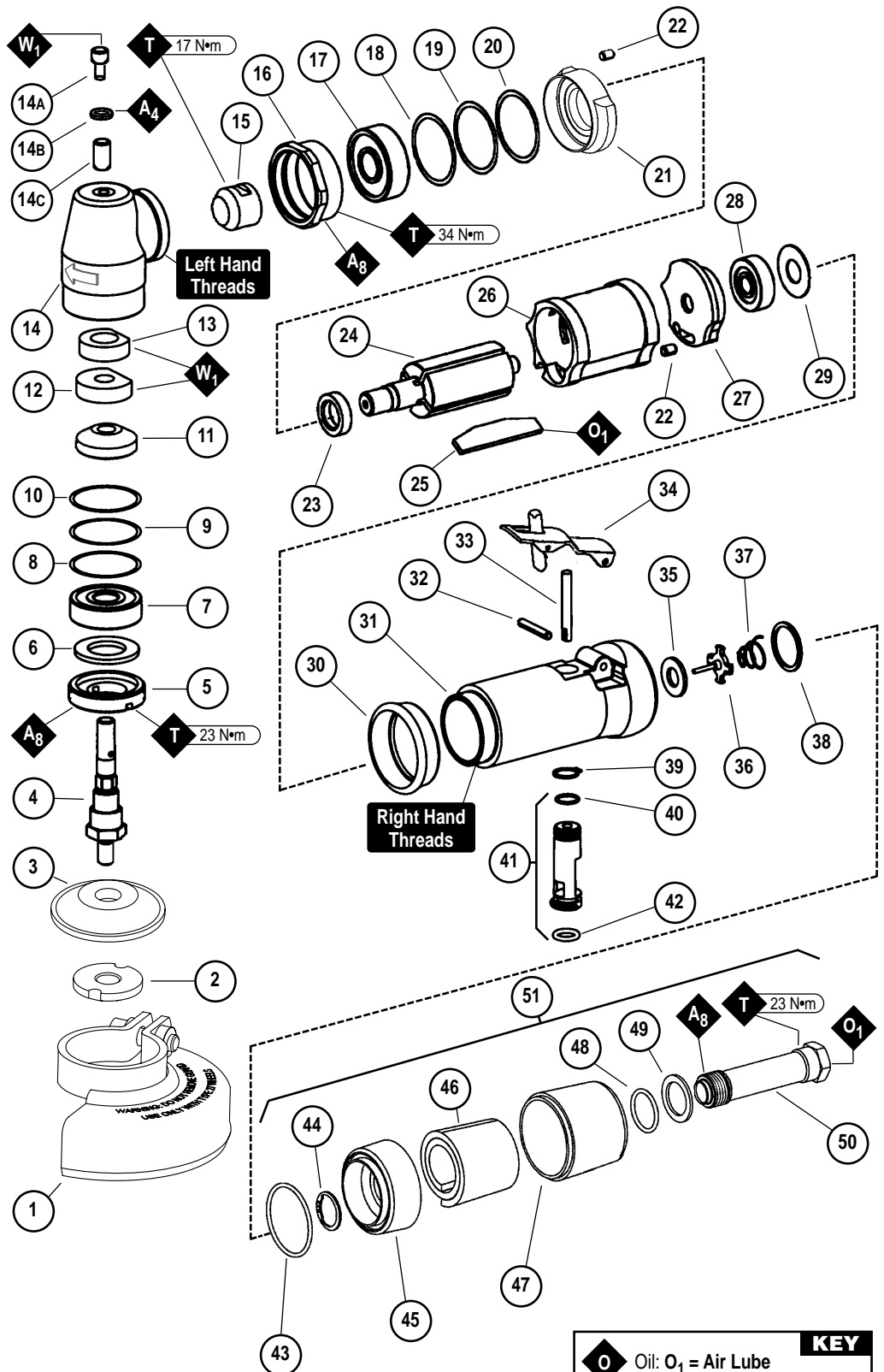

Disassembly/Assembly Instructions - Right Angle Tools

Important: Manufacturer's warranty is void if tool is disassembled before warranty expires.

Please refer to parts breakdown for part identification.

Angle-Head Disassembly:

1. Disconnect the tool from the air supply. **Important:** Hold the air inlet adapter securely with a wrench before removing the air fitting so as to prevent damage to the composite housing.
2. Use the **96148** Pin Wrench to remove the **50091** Flange. Remove any abrasive and the **50093** Back-Up Flange.
3. Secure the **02031** Housing in a vise by using the **52296** Repair Collar to provide protection for the housing. Position the housing so that the **02035** Lock Ring is facing up.
4. Use the **50971** Lock Ring Tool to remove the **02035** Lock Ring, by turning it counterclockwise.
5. Grasp the spindle to pull the spindle, the **54520** Bearing, the gear and the shims out of the housing.
6. The bearing and gear can be pressed off the spindle with the **96232**, #2 Arbor Press.
7. If necessary the **02033** Needle Bearing can be removed by using a 5/16" dia. flat end drive punch to push the **02041** Gear Oil Plate, and **01041** Gear Oil Fitting out of the **02031** Housing.

Angle-Head Disassembly Complete.

Motor Disassembly:

1. Disconnect the tool from the air supply. **Important:** Hold the air inlet adapter securely with a wrench before removing the air fitting so as to prevent damage to the composite housing.
2. Secure the motor housing in a vise by using the **52296** Repair Collar or padded jaws to provide protection for the housing. Position the tool so that the angle-head is pointing up.
3. Use a 34 mm or an adjustable wrench to remove the **01461** Lock Nut by turning it clockwise.
4. Pull the motor assembly out of the motor housing.
5. Fasten the **96346**, 2" Bearing Separator around the portion of the **01476** Cylinder that is closest to the **02676** Rear Bearing Plate.
6. Place the bearing separator on the table of the arbor press so that the pinion gear end of the rotor is pointing toward the floor.
7. Use a 3/16" dia. flat end drive punch as a press tool and position it on the rotor shaft. Press the rotor out of the **02696** Bearing. The **02696** Bearing can be removed from the **02676** Bearing Plate with the **96210** Bearing Removal Tool and the arbor press.
8. Secure the body of the rotor in a vise with bronze or aluminum jaws so that the pinion gear is pointing up.
9. Use a wrench to remove the pinion gear from the rotor by turning it counterclockwise.
10. Push the **02649** Bearing out of the front bearing plate and remove the shims.
11. Slip the **01479** Spacer off the rotor.

Motor Disassembly Complete.

Valve Disassembly:

1. Use the **52296** Repair Collar to securely hold the motor housing in a vise so that the inlet adapter is pointing up.
2. Remove the muffler assembly by loosening the inlet adapter. Remove the **01468** Spring, **01472** Tip Valve, and **01464** Seal. Refer to the parts breakdown for part identification and the sequence of disassembly for the muffler.
3. Reposition the motor housing in the vise so that the throttle lever, and the **12132** Pin are accessible. Remove the pin and lever by using a 2.5 mm dia. drive punch.
4. Use retaining ring pliers to remove the **95558** Retaining Ring and push the **01469** Speed Regulator Assembly out of the motor housing.

Valve Disassembly Complete.

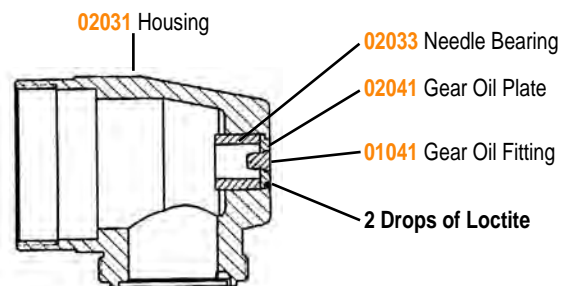

Important: Clean and inspect parts for wear or damage before assembling.

Valve Assembly:

1. Install the **01469** Speed Regulator Assembly into the motor housing, and secure it in place with the **95558** Retaining Ring.
2. Use the **52296** Repair Collar to securely hold the motor housing in a vise so that the air inlet is pointing up.
3. Insert the **01449** Valve Stem into the speed regulator assembly so that the hole in the valve stem aligns with the air inlet hole in the motor housing.
4. Install the **01464** Seal so that it lays flat. Use a needle nose pliers to grasp the nylon portion of the **01472** Tip Valve and install it so that the metal pin fits into the hole of the **01449** Valve Stem.
5. Install the **01468** Spring so that the smaller end fits against the back of the tip valve.
6. Refer to the parts breakdown for part identification and the sequence of assembly for the muffler. Apply a small amount of Loctite #567 (or equivalent) to the male threads of the inlet adapter and install the muffler assembly. Tighten the inlet adapter. (Torque to 23 N•m/200 in. lbs.)

Valve Body Assembly Complete.

Motor Assembly:

1. Secure the body of the rotor in a vise with bronze or aluminum jaws so that the threaded end is pointing up.
2. Slip the **01479** Spacer onto the **02037** Rotor.
3. Select .003 (.08mm) thick shims from the **54529** Shim Pack and place these into the **01478** Front Bearing Plate.
4. Install the **02649** Bearing into the front bearing plate and slip the bearing/plate assembly onto the rotor.
5. Install the pinion onto the rotor, making it hand tight.

(continued on next page)

Disassembly/Assembly Instructions - (continued)

6. Check the clearance between the rotor and the bearing plate with a .001 thick feeler gauge. Clearance should be .001" to .0015" (0.03-0.04mm). If it's necessary, readjust clearance by repeating steps 3-5 with different thickness shims.
7. Once the proper rotor/plate clearance is achieved wrench tighten the pinion. (Torque to 17N•m/150 in. lbs.)
8. Apply the **95842** Dynabrade Air Lube (10W/NR or equivalent) to the **01480** Blades and install them onto the rotor.
9. Use the **96216** Bearing Press Tool so that it pushes against the outer race of the **02696** Bearing and install it into the **02676** Rear Bearing Plate with the arbor press.
10. Place the pinion on the tool plate of the arbor press so that the rear portion of the rotor is pointing up.
11. Install the **01476** Cylinder so that it rests against the **01478** Bearing Plate. Note: Make sure that the air inlet passage of the cylinder will properly align with the air inlet passage in the **02676** Bearing Plate.
12. Use the **96216** Bearing Press Tool so that it pushes against the inner race of the **02696** Bearing and install the rear bearing/plate assembly onto the rotor with the arbor press. **Important:** Carefully press the rear bearing/plate assembly onto the rotor until it touches the **01476** Cylinder. A "snug" fit should exist between the bearing plates and cylinder. If it is too tight the rotor will not turn freely and will cause damage to the bearings. If it is too loose the proper bearing preload will not be achieved.
13. Apply a small amount of grease to the seal of the **02696** Rear Bearing and place the **02679** Shield against the seal of the bearing.
14. Install the motor assembly into the housing so that the air passage node of the rear bearing plate aligns with the air passage notch inside the housing.
15. Apply a small amount of Loctite #567 (or equivalent) to the threads of the motor housing and use a 34mm (or an adjustable wrench) to connect the angle-head assembly to the motor housing. (Torque to 34 N•m/300 in. lbs.)

Motor Assembly Complete.

Angle-Head Assembly:

1. Press the **01041** Gear Oil Fitting into the **02041** Gear Oil Plate.
2. Carefully apply two drops of Loctite #680 (or equivalent) to the recessed area of the **02031** Housing and press the gear oil plate along with gear oil fitting into the housing. (Allow 30 minutes for the adhesive to cure.)
3. Press the **02033** Needle Bearing into the housing.
4. Position the **96239** Bearing Press Tool so that it rests against the inner race of the **54520** Bearing and press the bearing onto the spindle.
5. Align the hex shaped I.D. area of the gear with that of the spindle and press the gear into place.
6. Apply a small amount of Loctite #567 (or equivalent) to the mating threads of the **02031** Housing. Connect these parts while being aware of the right and left hand threads.
7. Place the **52296** Repair Collar around the motor housing and position the tool in a vise so that the angle-housing end of the tool is pointing up.
8. Use a 34 mm or adjustable wrench on the **01461** Lock Nut while holding the angle housing stationary with one hand. **Note:** The throttle lever can be positioned in 360° to the desired location. Allow for additional rotation when tightening the lock nut. (Torque to 23 N•m/200 in. lbs.)
9. Reposition the tool assembly in the vise so that the opening in the angle housing, for the **02035** Lock Ring is facing up.
10. Soak the wicks in the **95848** Gear Oil before installing them into the **02031** Housing. Install the top wick first followed by the bottom wick. Position truncated side of each wick toward the end of the pinion gear.
11. Install the **02028** Spindle into the angle housing. Apply a slight amount of pressure down on the spindle while rotating it back and forth checking for the proper backlash or fit between the gears. A slight amount of backlash or clearance should exist between the bevel and pinion gears. When a tight fit exist, then add shims as needed placing the required thickness of shims between the outer race of the **54520** Bearing and the bearing seat in the housing.
12. Place (1) **01486** Felt Silencer into the **02035** Lock Ring, and apply a small amount of Loctite #567 (or equivalent) to the threads of the **02035** Lock Ring. Use the **50971** Lock Ring Wrench to install the lock ring onto the **02031** Housing. (Torque to 23 N•m/200 in. lbs.)
13. Install and orient **02059** 3" Wheel Guard Assembly, position to best protect operator.
14. Install flanges and abrasive following mounting procedure.

Angle-Head Assembly Complete.

Tool Assembly Complete. Please allow 30 minutes for adhesives to cure before operating tool.

Important: Before operating, place 2-3 drops of Dynabrade Air Lube (P/N **95842**) directly into air inlet with throttle lever depressed. Operate tool for 30 seconds to determine if tool is operating properly and to allow lubricating oils to properly penetrate motor. Motor should now be tested for proper operation at 90 PSIG. If motor does not operate properly or operates at a higher RPM than marked on the tool, the tool should be serviced to correct the cause before use. Loctite® is a registered trademark of Loctite Corp.

Special Greasing Instructions



- Lubricate wick system through the angle gear oil fitting with 2-3 plunges for every 24 hours of use, to achieve maximum gear life.

Important: Use only the recommended angle gear oil for the wick system. Do not contaminate the wick with any other oil or grease product.

(Order **95848** Gear Oil and **95541** Gun)

Preventative Maintenance Schedule

For Model 52705

This service chart is published as a guide to expectant life of component parts. The replacement levels are based on average tool usage over one year. Dynabrade Inc. considers one year usage to be 1,000 hours.

Parts Common to all Models:

LEGEND	
T	Included in Tune-Up Kit
X	Type of wear, no other comments apply.
L	Easily lost. Care during assembly/disassembly.
D	Easily damaged during assembly/disassembly.
R	Replace each time tool is disassembled.



96179 – Motor Tune-Up Kit

Index #	Part Number	Description	Number Required	High Wear 100%	Medium Wear 70%	Low Wear 30%	Non-Wear 10%
1	02059	3" Guard Assembly	1				X
2	50091	Flange	1				X
3	50093	Back-Up flange	1				X
4	02083	Spindle	1				X
5	02035	Lock Nut	1				X
6	01486	Felt Silencer	1	T			
7	54520	Bearing	1		T		
8	97116	Shim	1		T		
9	97117	Shim	1		T		
10	97118	Shim	1		T		
11	02597	Gear	1			X	
12	02044	Wick	1		T		
13	02045	Wick	1		T		
14	02031	Housing	1				X
14A	01041	Gear Oil Fitting	1			D	
14B	02041	Gear Oil Plate	1			X	
14C	02033	Needle Bearing	1			X	
15	02598	Pinion	1			X	
16	01461	Lock Nut	1			X	
17	02697	Bearing	1		X		
18	54543	Shim	1		T		
19	54544	Shim	1		T		
20	54551	Shim	1		T		
21	01478	Bearing Plate	1			X	
22	50767	Pin	2			X	
23	01479	Spacer	1			X	
24	02037	Rotor	1				X
25	01480	Blade (4/pkg.)	1	T			
26	01476	Cylinder	1			X	
27	02676	Bearing Plate	1			X	
28	02696	Bearing	1		T		
29	02679	Shield	1		T		
30	01547	Collar	1			X	
31	02058	Housing	1				X
32	12132	Pin	1		T		
33	01449	Valve Stem	1		T		
34	01462	Safety Throttle Lever	1			X	
35	01464	Seal	1		T		
36	01472	Tip Valve	1		T		
37	01468	Spring	1		T		
38	01564	Air Control Ring	1				L
39	95558	Retaining Ring	1	T			
40	95730	O-Ring	1				D
41	01469	Speed Regulator Assy.	1		T		
42	01024	O-Ring	1				D
43	95438	O-Ring	1			D	
44	95711	Retaining Ring	1	T			
45	94521	Muffler Base	1			X	
46	94528	Felt Muffler	1	T			
47	94522	Muffler Cap	1			X	
48	95375	O-Ring	1			L	
49	94526	Spacer	1			L	
50	94523	Inlet Adapter	1				X

Optional Accessories

FIND THE MOST CURRENT OFFERING OF SUPPORT DOCUMENTS AND ACCESSORIES @ WWW.DYNABRADE.COM



Dynamswivel®

- Swivels 360° at two locations which allows an air hose to drop straight to the floor, no matter how the tool is held.

94300 1/4" NPT.



Dynabrade Air Lube

- Formulated for pneumatic equipment.
- Absorbs up to 10% of its weight in water.
- Prevents rust and formation of sludge.
- Keeps pneumatic tools operating longer with greater power and less down time.

95842: 1 pt. (473 ml)

95843: 1 gal. (3.8 L)



95675 Male Plug

- Provides up to twice the air flow compared to standard plug design.
- Plug has "ported" design to prevent "starving" of the air tool.



Dynabrade Angle Gear Oil

- Specifically formulated to saturate wick system in right angle gear head.

95848: 2.5 oz. tube

95541: Gear Oil Gun

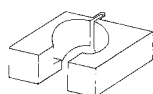

52296 Repair Collar

- Specially designed collar for use in vise to prevent damage to valve body of tool during disassembly/assembly.



96179 Motor Tune-Up Kit

- Includes assorted parts to help maintain and repair motor.



53621 Overhose Assembly

- Overhose Assembly directs exhaust away from operator.



Composite-Style Coupler

- Lightweight 1.4 oz. (.05 Kg), non-marring composite material.
- Easy connect/disconnect by single push-button action.
- Shock-proof, low-vibration, crush-resistant.

94960: 1/4" Female NPT

94980: 1/4" Male NPT

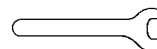

Open-End Wrench

95262 – 14mm open-end.



96148 – Pin Wrench

Reference Contact Information

1. American National Safety Institute – ANSI

25 West 43rd Street
Forth Floor
New York, NY **10036**
Tel: 1 (212) 642-4900
Fax: 1 (212) 398-0023

3. European Committee for Standardization

Rue de Stassart 36
B - 1050 Brussels, Belgium

2. Government Printing Office – GPO

Superintendent of Documents
Attn. New Orders
P.O. Box **371954**
Pittsburgh, PA **15250-7954**
Tel: 1 (202) 512-1803

Visit Our Web Site: www.dynabrade.com

Email: Customer.Service@Dynabrade.com



DYNABRADE, INC., 8989 Sheridan Drive • Clarence, NY **14031-1490** • Phone: (716) 631-0100 • Fax: 716-631-2073 • International Fax: 716-631-2524
DYNABRADE EUROPE S.à.r.l., Zone Artisanale • L-5485 Wormeldange—Haut, Luxembourg • Telephone: 352 76 84 94 1 • Fax: 352 76 84 95 1

©DYNABRADE, INC., 2005

PRINTED IN USA