

For Serial No. 9J1264 and Higher

Parts Page Reorder No. PD04•45  
Effective September, 2004  
Supersedes PD01•89

**Models:**

**13300** – 3,200 RPM

**13310** – Versatility Kit

**Mini-Dynisher®**

*Air Motor and Machine Parts, 3200 RPM*

**▲ WARNING**

Always operate, inspect and maintain this tool in accordance with the Safety Code for portable air tools (ANSI B186.1) and any other applicable safety codes and regulations. Please refer to Dynabrade's Warning/Safety Operating Instructions for more complete safety information. See inside for Important Operating, Maintenance and Safety Instructions.

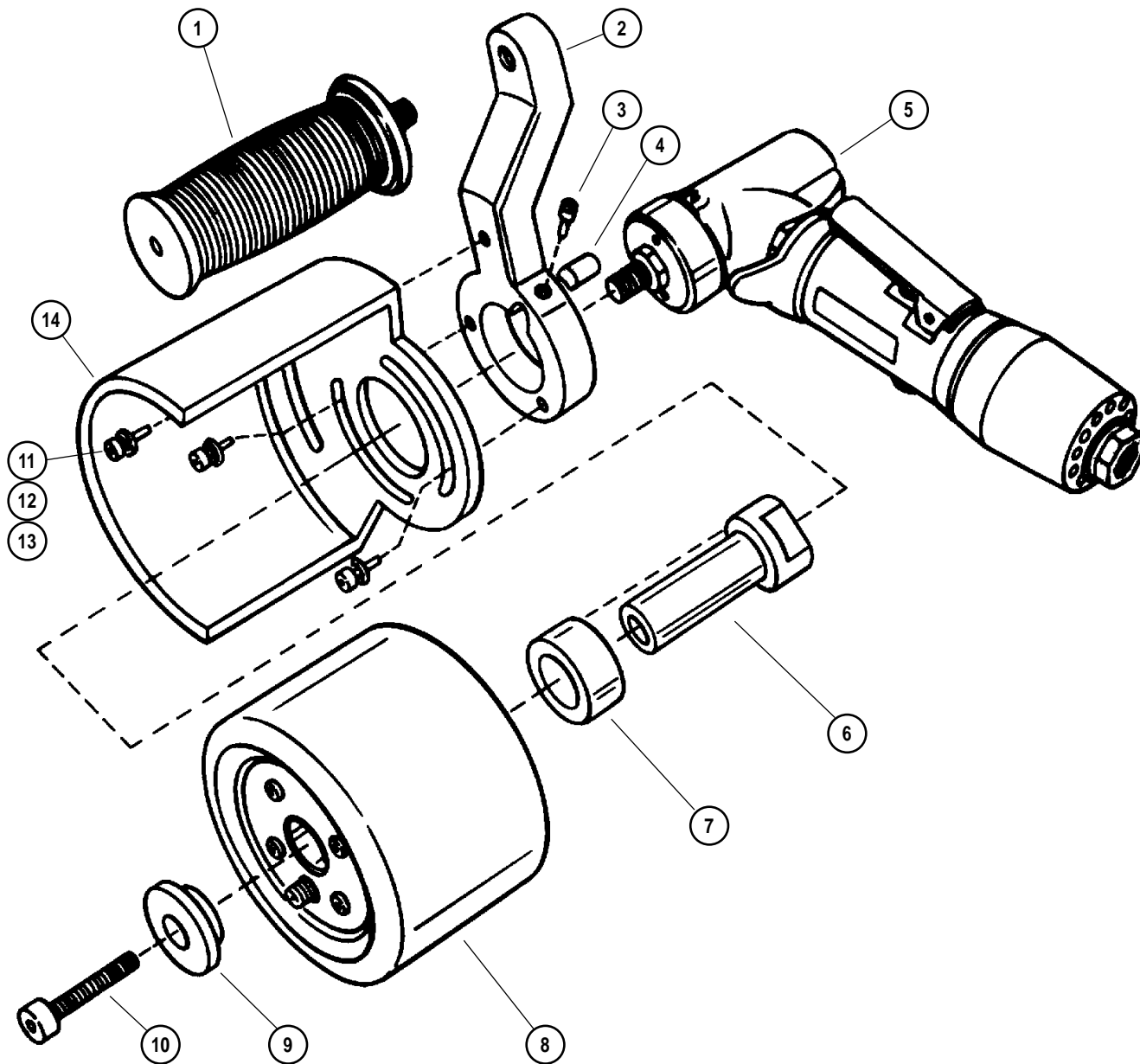

Index Key		
No.	Part#	Description
1	53163	Handle Assembly
2	53156	Handle Support
3	01678	Lock Screw
4	40029	Cam Lock
5	01986	Motor Assembly
6	53154	Spindle
7	13063	Spacer
8	94507	Pneumatic Wheel (not included)
9	13066	Flange
10	96133	Screw
11	95146	Flat Washer (3)
12	01211	Lock Washer (3)
13	97010	Screw (3)
14	53157	Shroud

## 01986 Motor Assembly

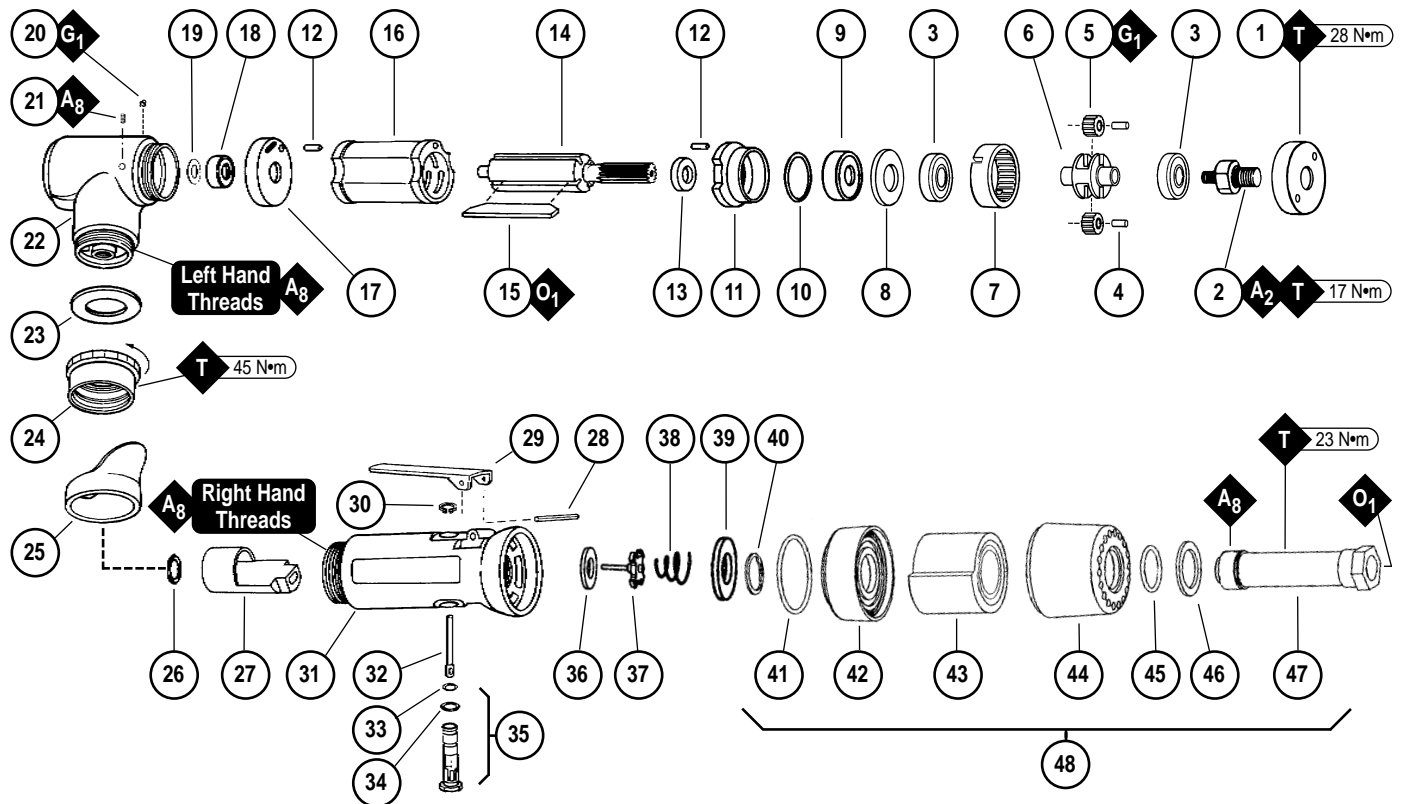

### Index Key

#### No. Part # Description

1	50781	Rear Exhaust Cover	17	02673	Rear Bearing Plate	33	95730	O-Ring
2	50782	Adapter	18	02696	Bearing	34	01024	O-Ring
3	54552	Bearing (2)	19	02679	Shield	35	01469	Speed Regulator Assy.
4	54472	Gear Shaft (2)	20	01041	Grease Fitting	36	01464	Seal
5	54519	3,200 RPM Gear (2)	21	50784	Set Screw	37	01472	Tip Valve
6	50786	Planetary Carrier	22	50776	Motor Housing	38	01468	Spring
7	54468	Ring Gear	23	01548	Gasket	39	01564	Air Control Ring
8	50778	Spacer	24	01461	Lock Nut	40	95711	Retaining Ring
9	02649	Bearing	25	01558	Collar	41	95438	O-Ring
10	54529	Shim (3/pkg.)	26	95523	O-Ring	42	94521	Muffler Base
11	01478	Front End Plate	27	01470	Insert	43	94528	Felt Muffler
12	50767	Pin (2)	28	12132	Pin	44	94522	Muffler Cap
13	01479	Spacer	29	01448	Throttle Lever	45	95375	O-Ring
14	54554	Rotor	30	95558	Retaining Ring	46	94526	Spacer
15	01480	Blade (4/pkg.)	31	02115	Housing - 13300	47	94523	Inlet Adapter
16	01476	Cylinder	32	01449	Valve Stem	48	94519	Muffler Assembly

KEY	
	Oil: O <sub>1</sub> = Air Lube
	Adhesive: A <sub>2</sub> = Loctite #271 A <sub>8</sub> = Loctite #567
	Torque: N•m x 8.85 = In. - lbs.
	Grease: G <sub>1</sub> = Lubriplate 630 AA

### Disassembly/Assembly Instructions - .4 Hp/7°/Rear Exhaust

**Important:** Manufacturer's warranty is void if tool is disassembled before warranty expires.

**Notice:** Dynabrade strongly recommends the use of the 52296 Repair Collar (sold separately) during assembly/disassembly of the Mini-Dynisher. All of the special repair tools referred to in these instructions can be ordered from Dynabrade. Please refer to parts page for proper part number identification.

#### Planetary Gear Disassembly:

1. Close off the air supply and disconnect the tool from the air supply.
2. Remove any abrasives and accessory from the 53154 Spindle.
3. Loosen the 01678 Lock Screw to remove the handle and shroud assembly.
4. Position the 52296 Repair Collar around the 02115 Housing and secure the tool in a vise so that the 53154 Spindle is pointing out.
5. Remove the 53154 Spindle by holding the 50782 Adapter stationary with a wrench and turning the spindle counterclockwise.
6. Use the 50971 Lock Ring Tool to remove the 50781 Rear Exhaust Cover by turning it counterclockwise.
7. Use the 96401 Hex Key (2mm) to remove the 50784 Set Screw.
8. Remove the planetary gear assembly 50776 Motor Housing.
9. Fasten the 96346 (2") Bearing Separator between the 54468 Ring Gear and the rear 54552 Bearing.
10. Place the planetary gear assembly and the separator on the table of the 96232 (#2) Arbor Press so that the 50782 Adapter is pointing down.
11. Carefully place the 96213 Bearing Removal Tool against the 50787 Planetary carrier removing it from the rear 54552 Bearing.
12. Remove the ring gear, shafts and gears from the planetary carrier.
13. Secure the planetary carrier in a vise with aluminum or bronze jaws so that the 50782 Adapter is pointing up. Apply heat and remove the adapter from the planetary carrier.

Planetary Gear Disassembly Complete.

#### Motor Disassembly:

1. Pull the motor assembly from the motor housing.
2. Remove the 50778 Spacer from the motor.

(continued on next page)

## Disassembly/Assembly Instructions - .4 Hp/7°/Rear Exhaust (continued)

- Fasten the 96346 Bearing Separator (2") around the rear portion of the 01476 Cylinder closest to the rear bearing plate.
- Place the separator and the motor assembly on the table of the 96232 Arbor Press so that the pinion gear of the rotor is pointing down. Use a 3/16" dia. flat end drive punch as a tool. Place it against the rear bearing journal of the rotor and push the rotor from the 02696 Bearing.
- Remove the 02679 Shield from the 02696 Bearing.
- Use the 96210 Bearing Removal Tool to remove the 02696 Bearing from the 02673 Rear Bearing Plate.
- Remove the 01480 Blades from the rotor.
- Press the 02649 Bearing from the rotor, removing the 01478 Front Bearing Plate and the 54529 Shims.
- Remove the 01479 Spacer from the rotor.

**Motor Disassembly Complete.**

### Valve Disassembly

- Place the 52296 Repair Collar around the 02115 Housing and secure it in a vise so that the 94523 Inlet Adapter is pointing up.
- Use two wrenches when removing the air fitting. Place one wrench on the 94523 Inlet Adapter to hold it stationary and use another wrench to remove the air fitting.
- Remove the inlet adapter from the housing by turning it counterclockwise. **Note:** Refer to the exploded view of the muffler assembly to identify the parts and their order of disassembly.
- Use needle nose pliers to remove the 01468 Spring and the 01472 Tip Valve. The 01464 Seal can be removed from the valve housing with a small screwdriver.
- Use a 2.5mm drive punch to remove the 12132 Pin and throttle lever.
- Use retaining ring pliers to remove the 95558 Retaining Ring and push the 01469 Speed Regulator Assembly along with the 01449 Valve Stem out of the valve housing.

**Valve Disassembly Complete.**

### Valve Assembly:

- Place the 52296 Repair Collar around the 02115 Housing and secure it in a vise so that the air inlet opening is pointing up.
- Install the 01469 Speed Regulator Assembly (includes o-rings) into the housing and secure it in place with the 95558 Retaining Pin.
- Insert the 01449 Valve Stem so that the end with the hole fits into the 01469 Speed Regulator Assembly.
- Install the 01464 Seal into the air inlet opening so that it lays flat.
- Use needle nose pliers to gasp the white nylon portion of the 01472 Tip Valve and insert the metal pin of the tip valve into the hole in the 01449 Valve Stem.
- Install the 01468 Spring so that the smaller end of the spring fits against the center of the tip valve.
- Note:** Refer to the exploded view of the muffler assembly to identify the parts and their order of assembly. Apply a small amount of the Loctite #567 (or equivalent) to the threads of the inlet adapter and install it into the air inlet opening of the housing. (Torque to 23 N•m/200 in.-lbs.)
- Install the throttle lever and secure it in place with the 12132 Pin.
- Use two wrenches when installing the air fitting. Place one wrench on the 94523 Inlet Adapter to hold it stationary and use another wrench to install the air fitting.

### Motor Assembly:

- Install the 01479 Spacer onto the rotor.
- Select .003 (.08mm) thick shims from the 54529 Shim Pack and place these into the 01478 Front Bearing Plate.
- Install the 02649 Bearing into the front bearing plate.
- Use the 96240 Bearing Press Tool (position the raised inside diameter against the inside diameter of the bearing) and the 96232 Arbor Press to install these parts onto the pinion end of the rotor.
- Check the rotor/plate clearance with a .001 (0.03mm) feeler gage. The clearance should be .001-.0015 (0.03-0.04mm). If the rotor/plate clearance needs adjustment, repeat steps 3-5 and shim as required.
- Apply the 95842 Dynabrade Air Lube (10W/NR or equivalent) to the 01480 Blades (4) and install these into the slots in the rotor.
- Install the 01476 Cylinder over the rotor so that the air inlet opening of the cylinder will align the air inlet opening of the 02673 Rear Bearing Plate.
- Use the 96216 Bearing Press Tool (position the raised outside diameter against the outside diameter of the bearing) and 96232 Arbor Press to install the 02696 Bearing into the rear bearing plate.
- Use the 96216 Bearing Press Tool (position the raised inside diameter against the inside diameter of the bearing) and 96232 Arbor Press to install these parts onto the rear bearing journal of the rotor. **Note:** Press the rear bearing/plate assembly down onto the rotor only until the 02673 Rear Bearing Plate comes in contact with the 01476 Cylinder. This fit will establish a preload on the motor bearings producing a "snug fit" between the bearings and the cylinder. If the fit is too tight it will cause the bearings to wear prematurely, too loose and the desired preload will not be achieved. If an adjustment is required disassemble and repeat steps 7-9.
- Apply a small amount of the 95542 Grease (or equivalent) to the seal of the 02696 Bearing and install the 02679 Shield against the bearing.
- Install the motor assembly into the 50776 Motor Housing.

**Motor Assembly Complete.**

### Planetary Gear Assembly:

- Use the 96239 Bearing Press Tool (position the raised inside diameter against the inside diameter of the bearing) and the 96232 Arbor Press to install the front 54552 Bearing(s) onto the female threaded end of the 50786 Planetary Carrier.
- Apply a small amount of the Loctite #271 (or equivalent) to the carrier threads of the 50782 Adapter and install the adapter onto the planetary carrier. (Torque to 17 N•m/150 in.-lbs.)
- Apply the 95542 Grease to the shafts, bearings and gears of the planetary carrier and install these parts.
- Orient the 54468 Ring Gear on the planetary carrier so that the set screw and grease fitting notches align properly with the openings in the 50776 Motor Housing once it's installed.
- Use the 96239 Bearing Press Tool (position the raised inside diameter against the inside diameter of the bearing) and the 96232 Arbor Press to install the rear 54552 Bearing onto the rear bearing journal of the 50786 Planetary Carrier. **Note:** Press the bearing down onto the carrier only until the 54552 Bearing comes in contact with the 54468 Ring Gear. This fit will establish preload on the bearings producing a "snug fit" between the bearings and the ring gear. If it fits too tight it will cause the bearings to wear prematurely, if the fit is too loose the desired preload will not be achieved. If an adjustment is required disassemble and repeat this step.
- Install the 50778 Spacer with the flat side of the spacer against the 02649 Bearing of the motor assembly.
- Slide the planetary gear assembly into the 50776 Motor Housing so that the set screw and grease fitting notches align with the corresponding openings in the housing.
- Apply a small amount of the Loctite #567 (or equivalent) to the 50784 Set Screw and install it into the housing.
- Apply a small amount of the Loctite #567 (or equivalent) to the threads of the motor housing and install the 50781 Rear Exhaust Cover. (Torque to 28 N•m/250 in.-lbs.)
- Lubricate the planetary gear assembly with the 95542 Grease through the grease fitting. Use the 95541 Grease Gun to initially apply 2-3 plunges of grease and there after 2-3 plunges for every 50 hours of use.
- Install the 53154 Spindle.

**Planetary Gear Assembly Complete. Tool Assembly Complete. Please allow 30 minutes for adhesives to cure before operating tool.**

**Important:** Motor should now be tested for proper operation at 90 PSIG. If motor does not operate properly or operates at a higher RPM than marked on the tool, the tool should be serviced to correct the cause before use. Before operating, place 2-3 drops of Dynabrade Air Lube (P/N 95842) directly into air inlet with throttle lever depressed. Operate tool for 30 seconds to determine if tool is operating properly and to allow lubricating oils to properly penetrate motor.

### Pneumatic Wheel/Abrasive Wheel Installation:

#### 94507 Pneumatic Wheel:

- Remove 96133 Screw and 13066 Flange with 3mm hex key. Install 94507 Pneumatic Wheel (with air inlet facing out) onto spindle. **Note:** Be sure 13063 Spacer is located on spindle behind pneumatic wheel.
- Tighten 96133 Screw and flange onto spindle to secure pneumatic wheel. Install abrasive belt and inflate (20 PSIG max).

**Abrasive Wheel:** (must have 5/8" bore and cannot exceed 4" dia. x 3" wide)

- Remove 96133 Screw and 13066 Flange with 3mm hex key, install wheel. Use 13063 Spacer for wheel less than 3" wide.
- Tighten 96133 Screw and flange onto spindle to secure wheel.

Loctite® is a registered trademark of Loctite Corp.

Model Number	Motor HP (W)	Motor RPM	Sound Level	Air Flow Rate CFM/SCFM (LPM)	Air Pressure PSIG (Bars)	Wheel (Dia. x Length)	Weight Pound (kg)	Length Inch (mm)	Height Inch (mm)
All Models	.4 (298)	3,200	80 dB(A)	3/21 (595)	90 (6.2)	3-1/4" x 3"	2.8 (1.3)	10 (254)	7 (178)

Additional Specifications: Air Inlet Thread 1/4" NPT • Hose I.D. Size 1/4" or 8mm

## Important Operating, Maintenance and Safety Instructions

Carefully read all instructions before operating or servicing any Dynabrade® Abrasive Power Tool.

**Warning:** Hand, wrist and arm injury may result from repetitive work motion and overexposure to vibration.

**Important:** All Dynabrade rotary vane air tools must be used with a Filter-Regulator-Lubricator to maintain all warranties.

### Operating Instructions:

**Warning:** Eye, face, respiratory, sound and body protection must be worn while operating power tools. Failure to do so may result in serious injury or death. Follow safety procedures posted in workplace.

1. With power source disconnected from tool, securely fasten abrasive/accessory on tool.
2. Install air fitting into inlet bushing of tool. **Important:** Secure inlet bushing of tool with a wrench before attempting to install the air fitting to avoid damaging valve body housing.
3. Connect power source to tool. Be careful not to depress throttle lever in the process.
4. Air tools are not intended for use in explosive atmospheres and are not insulated for contact with electrical power sources. Sanding/Grinding certain materials can create explosive dust. It is the employers responsibility to notify the user of acceptable dust levels. Sanding/Grinding can cause sparks which can cause fires or explosions. It is the users responsibility to make sure the work area is free of flammable materials.

### Maintenance Instructions:

1. Check tool speed regularly with a tachometer. If tool is operating at a higher speed than the RPM marked on the tool or operating improperly, the tool should be serviced to correct the cause before use.
2. Some silencers on air tools may clog with use. Clean and replace as required.
3. All Dynabrade rotary vane air motors should be lubricated. Dynabrade recommends one drop of air lube per minute for each 10 SCFM (example: if the tool specifications state 40 SCFM, set the drip rate of your filter-lubricator at 4 drops per minute). Dynabrade Air Lube (P/N **95842**: 1 pt. 473 ml.) is recommended.
4. It is strongly recommended that all Dynabrade rotary vane air tools be used with a Filter-Regulator-Lubricator to minimize the possibility of misuse due to unclean air, wet air or insufficient lubrication. Dynabrade recommends the following: **11405** Air Line Filter-Regulator-Lubricator — Provides accurate air pressure regulation, two-stage filtration of water contaminants and micro-mist lubrication of pneumatic components. Operates 40 SCFM @ 100 PSIG has 3/8" NPT female ports.
5. Lubricate planetary gears through the gear casing grease fitting with 2-3 plunges for every 50 hours of use, to achieve maximum gear life (**order 95542 Grease and 95541 Gun**).
6. Use only genuine Dynabrade replacement parts. To reorder replacement parts, specify the **Model #**, **Serial #** and **RPM** of your machine.
7. A Motor Tune-Up Kit (P/N **96174**) is available which includes assorted parts to help maintain motor in peak operating condition. Please refer to Dynabrade's Preventative Maintenance Schedule for a guide to expectant life of component parts.
8. Mineral spirits are recommended when cleaning the tool and parts. Do not clean tool or parts with any solvents or oils containing acids, esters, keytones, chlorinated hydrocarbons or nitro carbons.

### Safety Instructions:

Products offered by Dynabrade should not be converted or otherwise altered from original design without expressed written consent from Dynabrade, Inc.



- **Important:** User of tool is responsible for following accepted safety codes such as those published by the American National Standards Institute (ANSI).
- Operate machine for one minute before application to workpiece to determine if machine is working properly and safely before work begins.
- Always disconnect power supply before changing abrasive/accessory or making machine adjustments.
- Inspect abrasives/accessories for damage or defects prior to installation on tools.
- Please refer to Dynabrade's Warning/Safety Operating Instructions Tag (Reorder No. **95903**) for more complete safety information.
- **Warning:** Hand, wrist and arm injury may result from repetitive work, motion and overexposure to vibration.

### Notice

All Dynabrade motors use the highest quality parts and metals available and are machined to exacting tolerances. The failure of quality pneumatic motors can most often be traced to an unclean air supply or the lack of lubrication. Air pressure easily forces dirt or water contained in the air supply into motor bearings causing early failure. It often scores the cylinder walls and the rotor blades resulting in limited efficiency and power. Our warranty obligation is contingent upon proper use of our tools and cannot apply to equipment which has been subjected to misuse such as unclean air, wet air or a lack of lubrication during the use of this tool.

### One Year Warranty

Following the reasonable assumption that any inherent defect which might prevail in a product will become apparent to the user within one year from the date of purchase, all equipment of our manufacture is warranted against defects in workmanship and materials under normal use and service. We shall repair or replace at our factory, any equipment or part thereof which shall, within one year after delivery to the original purchaser, indicate upon our examination to have been defective. Our obligation is contingent upon proper use of Dynabrade tools in accordance with factory recommendations, instructions and safety practices. It shall not apply to equipment which has been subject to misuse, negligence, accident or tampering in any way so as to affect its normal performance. Normally wearable parts such as bearings, contact wheels, rotor blades, etc., are not covered under this warranty.

### Optional Accessories



#### Dynabrade Air Lube

- Formulated for pneumatic equipment.
- Absorbs up to 10% of its weight in water.
- Prevents rust and formation of sludge.
- Keeps pneumatic tools operating longer with greater power and less down time.

**95842:** 1 pt. (473 ml)

**95843:** 1 gal. (3.8 L)



#### 95542 Grease 10 oz.

- Multi-purpose grease for all types of bearings, cams, gears.
- High film strength; excellent resistance to water, steam, etc.
- Workable range 0° F to 300° F.

#### 95541 Push-type Grease Gun

- One-hand operation.



#### 50971 Lock Ring Tool

- Lock ring Tool has a 3/8 in. square socket for use with 3/8 in. drive; breaker bar, ratchet head, or torque wrenches.



#### 96174 Tune-Up Kit

- Includes assorted parts to help maintain and repair motor.

Visit Our Web Site: [www.dynabrade.com](http://www.dynabrade.com)

Email: [Customer.Service@Dynabrade.com](mailto:Customer.Service@Dynabrade.com)



**DYNABRADE, INC.,** 8989 Sheridan Drive • Clarence, NY 14031-1490 • Phone: (716) 631-0100 • Fax: 716-631-2073 • International Fax: 716-631-2524  
**DYNABRADE EUROPE S.à.r.l.,** Zone Artisanale • L-5485 Wormeldange—Haut, Luxembourg • Telephone: 352 76 84 94 1 • Fax: 352 76 84 95 1

© DYNABRADE, INC., 2006

PRINTED IN USA

Rev.1\_PD04.45\_06/06