

Dynafire® III

Air Motor and Machine Parts

Model:

15360 - .7 Hp

WARNING

Always operate, inspect and maintain this tool in accordance with the Safety Code for portable air tools (ANSI B186.1) and any other applicable safety codes and regulations. Please refer to Dynabrade's Warning/Safety Operating Instructions for more complete safety information.

Index Key

No.	Part #	Description
1	95567	Screw
2	11016	Bearing (2)
3	15358	Contact Wheel
4	11017	Spacer
5	15377	Contact Arm Tip
6	95311	Screw (2)
7	15368	Contact Arm
8	96334	Plug
9	15308	Guide Post
10	11040	Spring
11	15306	Tension Arm
12	95218	Knob
13	95426	Spring
14	15307	Tension Shaft
15	15309	Dust Cover
16	15329	Screw
17	15310	Guard
18	15312	Guard Assembly
19	96335	Hex Nut
20	15374	Housing
21	40029	Motor Lock
22	15336	Drive Wheel
23	15378	Motor Assembly
24	95217	Screw (5)
25	15373	Side Handle Block
26	53163	Handle Assembly
27	15315	Exhaust Cover
28	04078	Felt Silencer
29	01126	Air Control Ring
30	42636	Spindle Adapter
31	01007	Bearing
32	01121	Shim Pack (3/pkg.)
33	01010	Spacer
34	01008	Bearing Plate
35	50767	Pin (2)
36	01028	Cylinder
37	55021	Rotor
38	01185	Blade (4/pkg.)
39	01722	Bearing Plate
40	02649	Bearing
41	01295	Housing
42	01247	Speed Regulator Assembly
43	01024	O-Ring
44	95730	O-Ring
45	01477	Valve Stem
46	01464	Seal
47	01472	Tip Valve
48	01468	Spring
49	96065	O-Ring
50	53190	Block Plate
51	01494	Inlet Bushing
52	95558	Retaining Ring
53	01089	Safety Lock Lever
54	01017	Pin

15360 Tool Assembly

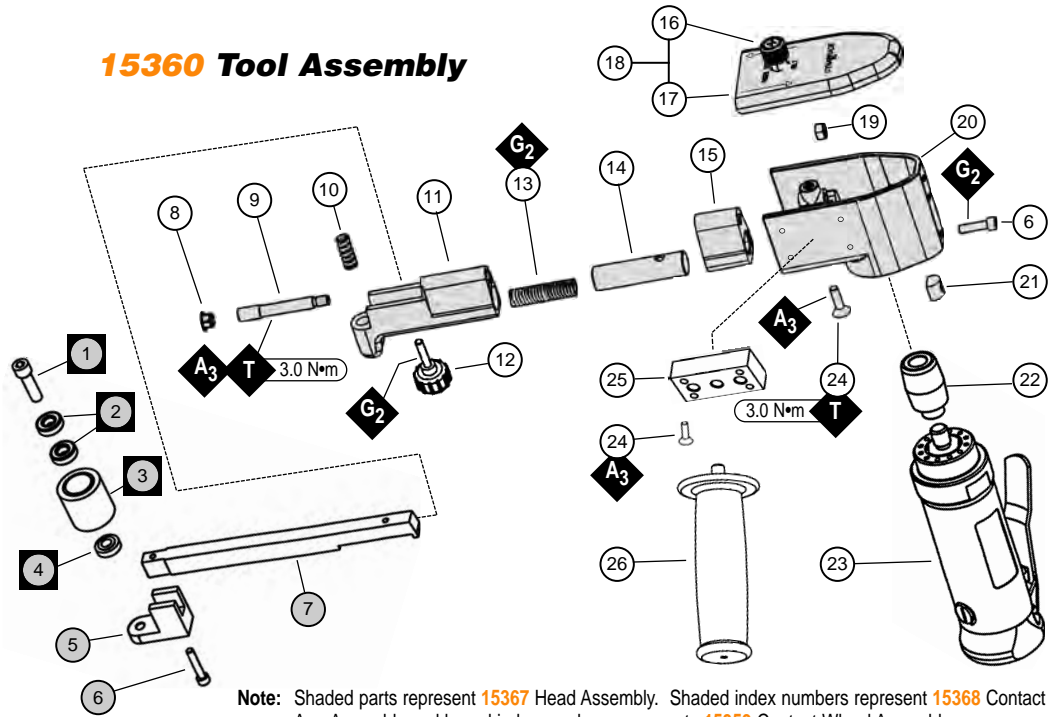

Note: Shaded parts represent 15367 Head Assembly. Shaded index numbers represent 15368 Contact Arm Assembly and boxed index numbers represents 15359 Contact Wheel Assembly.

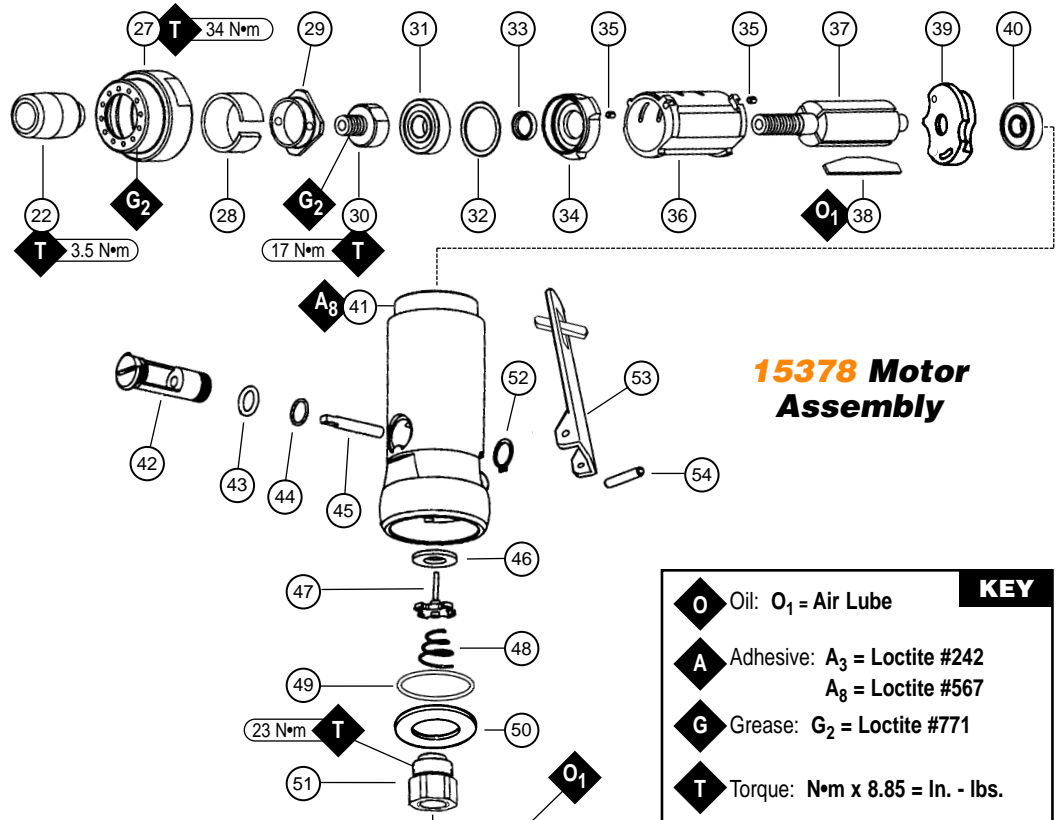

15378 Motor Assembly

KEY	
O	Oil: O ₁ = Air Lube
A	Adhesive: A ₃ = Loctite #242 A ₈ = Loctite #567
G	Grease: G ₂ = Loctite #771
T	Torque: N•m x 8.85 = In. - lbs.

Important Operating, Maintenance and Safety Instructions

Carefully read all instructions before operating or servicing any Dynabrade® Abrasive Power Tool.

Warning: Hand, wrist and arm injury may result from repetitive work motion and overexposure to vibration.

Important: All Dynabrade Rotary Vane air tools must be used with a Filter-Regulator-Lubricator to maintain all warranties.

Operating Instructions:

Warning: Eye, face, respiratory, sound, and body protection must be worn while operating power tools. Failure to do so may result in serious injury or death. Follow safety procedures posted in workplace.

1. With power source disconnected from tool, securely fasten abrasive/accessory on tool.
2. Connect power source to tool. Be careful **not** to depress throttle lever in the process.
3. Check tool speed with tachometer. If tool is operating at a higher speed than the RPM marked on the tool or operating improperly, the tool should be serviced to correct the cause before use.
4. Always work off the return side of the abrasive belt. This will ensure superior tracking and reduce down time of tool.

Abrasive Belt/Contact Arm Change Instructions:

To Change Belt:

1. Disconnect power source.
2. Remove cover.
3. Pull back on tension arm assembly.
4. Remove and replace abrasive belt and cover.
5. Connect power source.
6. Adjust belt tracking by turning **95218** Rough Adjustment Knob to the left or right accordingly while machine is running.

To Change Contact Arm Assembly:

1. Disconnect power source.
2. Remove cover.
3. Pull back on tension arm assembly and remove abrasive belt.
4. Remove **95218** Rough Adjustment Knob.
5. Remove contact arm and replace with desired arm, making sure that the tab on the end of the arm is facing downward.
6. Replace **95218** Knob.
7. Install abrasive belt and cover.
8. Connect power source and adjust belt tracking by turning **95218** Knob to the left or right accordingly while machine is running.

Housing Angle Adjustment:

To pivot housing, loosen **95311** Screw on housing with the supplied 9/64" hex wrench (P/N – **95134**). Pivot housing to desired angle and retighten **95311** Screw.

Maintenance Instructions:

Products offered by Dynabrade should not be converted or otherwise altered from original design without the expressed written consent from Dynabrade, Inc.

1. All Dynabrade Rotary Vane air motors should be lubricated. Dynabrade recommends one drop of air lube per minute for each 10 SCFM (example: if the tool specifications state 40 SCFM, set the drip rate of your filter-lubricator at 4 drops per minute). Dynabrade Air Lube (P/N **95842**: 1pt. 473ml.) is recommended.
2. An Air Line Filter-Regulator-Lubricator must be used with this air tool to maintain all warranties. Dynabrade recommends the following: **11405** Air Line Filter-Regulator-Lubricator — Provides accurate air pressure regulation, two-stage filtration of water contaminants and positive-drip lubrication of pneumatic components. Operates 40 SCFM @ 100 PSIG has 3/8" NPT female ports.
3. Frequent drainage of water traps in air lines is recommended.
4. Some silencers on air tools may clog with use. Clean and replace as required.
5. A Motor Tune-Up Kit (P/N **96529**) is available which includes assorted parts to help maintain and repair motor.

Note: Tune-Up Kit includes a **94525** Silencer which has to be cut down to the size of a **04078** Silencer.

Safety Instructions:

Products offered by Dynabrade should not be converted or otherwise altered from original design without expressed written consent from Dynabrade, Inc.



- **Warning:** Eye, face and body protection must be worn while operating power tools. Failure to do so may result in serious injury or death. Follow safety procedures posted in workplace.
- **Important:** User of tool is responsible for following accepted safety codes such as those published by the American National Standards Institute (ANSI).
- Tool RPM must never exceed abrasive/accessory RPM rating, regardless of tool capacity.
- Operate machine for 30 seconds before application to workpiece to determine if machine is working properly and safely before work begins.
- Always use proper guards. Make sure guards are in proper position, secure and in good repair.
- Always disconnect power supply before changing abrasive or making machine adjustments.
- Inspect abrasives and accessories for damage or defects prior to installation on tools.
- Please refer to Dynabrade's Warning/Safety Operating Instructions Tag (Reorder No. **95903**) for more complete safety information.
- **Warning:** Hand, wrist and arm injury may result from repetitive work, motion and overexposure to vibration.

Model Number	Motor hp (W)	Motor RPM	Sound Level	Abrasive Belt Size Inch (mm)	Maximum Air Flow CFM/SCFM (LPM)	Max. SFPM (SMPM)	Weight Pound (kg)	Length Inch (mm)	Height Inch (mm)
15360	.7 (522)	23,000	91 dB(A)	1 (25)W x 24 (610)L	5/34 (906)	4,550 (1,382)	3.35 (1.52)	12-3/4 (324)	7-1/8 (181)

Additional Specifications: Air Inlet Thread 1/4" NPT • Hose I.D. Size 3/8" or 10 mm • Air Pressure 90 PSIG (6.2 Bars)

Assembly/Disassembly for Dynafire® III

Important: Manufacturer's warranty is void if tool is disassembled before warranty expires.

To Disassemble:

1. Remove belt guard, abrasive belt and contact arm assembly. Loosen **95311** Screw and remove belt housing assembly from air motor.

Motor Disassembly:

Important: Do not over tighten vise or housing could be damaged.

1. Secure tool in a vise using wrench flats on the air inlet end of the housing.
2. Twist the drive wheel counterclockwise and remove. Using a wrench remove **15315** Exhaust Cover (twist counterclockwise). Remove silencer.
3. Pull motor assembly from housing. Fasten a bearing separator around the **01028** Cylinder, end nearest the **01244** Rear Bearing Plate.
4. Place the bearing separator on the table of the arbor press, so that the spindle of the motor is pointing towards the floor.
5. Using a 3/16" diameter drive punch as a press tool, press the rear portion of the **55025** Rotor out of the **02649** Rear Bearing.
6. Remove the cylinder and blades.
7. Secure the rotor body in a soft jaw (aluminum or bronze) vise. Remove the **42636** Spindle Adapter turning it counterclockwise. Also, remove the **01008** Front Bearing Plate along with **01007** Front Bearing, **01121** Shims, and **01010** Spacer.

Motor Disassembly Complete.

Valve Disassembly:

1. Secure motor housing in vise with air inlet bushing facing upwards.
2. Unscrew **01494** Inlet Bushing from valve body and remove **53190** Block Plate.
3. Using needle nose pliers, remove **01468** Spring and **01472** Tip Valve. Pick out **01464** Seal.
4. Using a 2.5 mm dia. drift pin, tap out **01017** Pin and remove throttle lever.
5. Remove **95558** Retaining Ring using retaining ring pliers.
6. Push **01247** Speed Regulator from housing.

Belt Housing Disassembly:

1. Unscrew **15329** Screw and remove **15312** Belt Guard Assembly, abrasive belt and contact arm assembly.
2. Loosen **95311** Screw and remove air motor.
3. Remove **96334** Plug.
4. Remove **15308** Guide Post and **96335** Hex Nut, this will release **15306** Tension Arm and **95426** Spring. (Heating of **96335** Nut may be required).
Warning: **15306** Tension Arm is spring loaded, use caution when removing **15308** Guide Post.
5. Remove **15309** Dust Cover, **95217** Screw and **15307** Tension Shaft. (Heating of **95217** Screw may be required).

Motor Assembly:

Important: Make sure parts are clean and in good condition before assembling.

1. Place **55025** Rotor in soft jaw (aluminum or bronze) vise with threaded spindle pointing upwards. Slip **01010** Spacer onto rotor.
2. Place a .002" shim into **01008** Front Bearing Plate as an initial spacing and slip **01007** Bearing into plate
Note: Shim Pack contains .001" and .002" shims.
3. Install bearing/bearing plate assembly onto rotor. Tighten **42636** Spindle Adapter onto rotor (torque to 17 N•m/150 in. - lbs.).
4. Check clearance between rotor and bearing plate by using a .001" feeler gauge. Clearance should be at .001" to .0015". Adjust clearance by repeating steps 1-4 with different shim if necessary.
5. Once proper rotor/gap clearance is achieved, install well lubricated **01185** Blades (4) into rotor slots. Dynabrade recommends their Air Lube P/N **95842**.
6. Install cylinder over rotor. Be sure air inlet holes of cylinder face away from front bearing plate and that the **50767** Pin in the front bearing plate aligns correctly with the pin-hole in the cylinder.
7. Press **02649** Rear Bearing into **01244** Rear Bearing Plate. Press rear bearing/bearing plate assembly onto rotor. Be sure that pin and air inlet holes line-up with pin slot and air inlet holes in cylinder. **Important:** Fit must be snug between bearing plates and cylinder. A loose fit will not achieve the proper preload of motor bearings. If too tight, rotor will not turn freely and must then be lightly tapped at press fit end so it will turn freely while still maintaining a snug fit.
8. Secure housing in vise using wrench flats on housing so motor cavity faces upwards.
9. Install motor assembly into housing (be sure motor drops all the way in). Tighten exhaust cover onto motor housing (torque 34 N•m/300 in. - lbs.).
10. Motor adjustment must now be checked. With motor housing still mounted in vise, pull end of rotor and twist (10-15 lbs. force), rotor should turn freely without drag. If drag or rub is felt, then increase preload or remove shim. Also, push end of rotor and twist (10-15 lbs. force), rotor should turn freely without drag. If drag or rub is felt, then deload or add shim.
11. Tighten **15336** Drive Wheel onto rotor (torque 3.38 N•m/30 in. - lbs.).

Motor Assembly Complete.

Valve Assembly:

1. Insert **01247** Speed Regulator Assembly and **01477** Valve Stem into valve body housing. Secure with **95558** Retaining Ring.
2. Secure valve body assembly in vise using wrench flats with air inlet facing upward and throttle lever accessible. (Torque 34.0 N•m/300 in. lbs.).
3. Insert **01464** Seal into housing.
4. Line up the hole in **01477** Valve Stem with the hole in the housing (looking past brass bushing). Using needle nose pliers, insert **01472** Tip Valve so that the metal pin passes through the hole in the **01447** Valve Stem.
5. Install **01468** Spring (small end first) over tip valve.
6. Install **53190** Block Plate and **96065** O-Ring onto **01494** Inlet Bushing.

(Continued on next page)

Assembly/Disassembly for Dynaflex® III (continued)

7. Apply small amount of #567 Loctite® (or equivalent) to threads of **01494** Inlet Bushing and install into valve body.
8. Install **01089** Throttle Lever and **01017** Pin. Remove valve body assembly from vise.

Housing Assembly:

1. Place **15307** Tension Shaft into housing.
2. Apply one drop of #242 Loctite® (or equivalent) to **95217** Screw and tighten (torque to 3.0 N•m/28 in. lbs.). (Refer to housing diagram for proper location of **95217** Screw).
3. Install **15310** Dust Cover onto **15307** Tension Shaft.
4. Lubricate (#771 Loctite® or equivalent) inside of **15307** Tension Shaft and inside larger diameter of **15306** Tension Arm.
5. Install **95426** Spring into **15307** Tension Shaft and place **15306** Tension Arm over **95426** Spring.
6. Place **15308** Guide Post into **15306** Tension Arm, apply one drop of #242 Loctite® (or equivalent) to screw threads.
7. Compress tension arm and secure in place with **96335** Nut. (Torque to 3.0 N•m/300 in. lbs.)
8. Press **96334** Plug into **15306** Tension Arm.
9. With **40029** Motor Lock in place, install air motor assembly into housing and secure in place with lubricated (#771 Loctite® or equivalent) **95311** Screw.
10. Complete assembly by installing contact arm assembly, abrasive belt and place **15310** Belt Guard Assembly over **15305** Housing, tighten **15329** Screw into **15305** Housing.

Housing Angle Adjustment:

1. Disconnect power source.
2. To pivot housing, loosen **95311** Motor Lock Screw on housing with the supplied 3/16" hex wrench (P/N – **95134**).
3. Pivot housing to desired angle and retighten the **95311** Motor Lock Screw.

Tool Assembly Complete. Please allow 30 minutes for adhesives to cure before operating tool.

Note: Motor should operate at between 21,000 and 23,000 RPM at 90 PSIG (6.2 Bar). RPM should be checked with a tachometer. Before operating, we recommend that 2-3 drops of Dynabrade Air Lube P/N – **95842** (or equivalent) be placed directly into the air inlet with the throttle lever depressed. Throttle lever is preset at the factory at an 1:00 o'clock position. **Important:** The regular maintenance of any air tool will contribute to greater efficiency of tool and will prolong tool life. The failure of quality pneumatic air motors can most often be traced to an unclean air supply or the lack of lubrication. Air pressure easily forces dirt or water contained in the air supply into motor bearings causing early failure. It often scores the cylinder walls and the rotor blades resulting in limited efficiency and power. Frequent drainage of water traps in air lines is recommended. Each tool on each drop should also be equipped with a secondary air processing unit. This consists of an in-line Filter-Regulator-Lubricator. All Dynabrade Rotary Vane air tools must be used with a Filter-Regulator-Lubricator to maintain all warranties. Our warranty obligation is contingent upon proper use of our tools and cannot apply to equipment which has been subject to misuse such as unclean air, wet air or a lack of lubrication during the use of the tool.

Loctite® is a registered trademark of the Loctite Corp.

Optional Accessories



80020 Dynamount Universal Benchmount

- Frees an operators hands for complete control of a workpiece.
- Optional **80015** Foot Switch and hose assembly provides on-off foot control of air-tool operation.



96529 Tune-Up Kit

- Includes assorted parts to help maintain and repair motor.

Note: Included silencer will have to be cut down to match **04078** Silencer.



Dynaswivel®

- Swivels 360° at two locations which allows an air hose to drop straight to the floor, no matter how the tool is held.

94300 1/4" NPT

Visit Our Web Site: www.dynabrade.com

Email: Customer.Service@Dynabrade.com



DYNABRADE, INC., 8989 Sheridan Drive • Clarence, NY 14031-1490 • Phone: (716) 631-0100 • Fax: 716-631-2073 • International Fax: 716-631-2524
DYNABRADE EUROPE S.à.r.l., Zone Artisanale • L-5485 Wormeldange—Haut, Luxembourg • Telephone: 352 76 84 94 1 • Fax: 352 76 84 95 1

©DYNABRADE, INC., 2001

PRINTED IN USA