

For Serial No. 06B1000 and Higher

AUTOMOTIVE

Parts Page Reorder No. APD07•05
Effective August, 2007
Supersedes APD06•02

Model:
10127 - 3" Dynabuffer

3" Dynabuffer

Air Motor and Machine Parts



Always operate, inspect and maintain this tool in accordance with the Safety Code for portable air tools (ANSI B186.1) and any other applicable safety codes and regulations. Please refer to Dynabrade's Warning/Safety Operating Instructions for more complete safety information.

Index Key

No.	Part #	Description
1	56145	3" Pad
2	51361	Shroud
3	95630	Snap Ring
4	57069	Balancer Shaft
5	95628	Bearing Shield
6	56053	Bearing Seal
7	56052	Bearing
8	57422	Motor Shaft Balancer
9	56047	Key
10	56046	Lock Ring
11	50659	O-Ring
12	57088	Bearing
13	51366	Bearing Plate
14	57113	Rotor/Blade (5/pkg.) Set
15	58358	Cylinder Assembly (Includes 98462 Pin)
16	98462	Pin
17	51367	Bearing Plate
18	01206	Bearing
19	95626	Retaining Ring
20	97166	Hang Plate
21	02099	Housing
22	01548	Gasket
23	01461	Lock Nut
24	01547	Collar
25	95523	O-Ring
26	01470	Insert Assembly
27	10139	Housing - 10127
28	01448	Throttle Lever
	01462	Safety Lock Lever (Opt.)
29	12132	Pin
30	01449	Valve Stem
31	95558	Retaining Ring
32	95730	O-Ring
33	01024	O-Ring
34	01469	Speed Regulator Assy.
35	01464	Seal
36	01472	Tip Valve
37	01468	Spring
38	01543	Air Control Ring
39	95711	Retaining Ring
40	95438	O-Ring
41	94521	Muffler Base
42	94528	Felt Muffler
43	94522	Muffler Cap
44	95375	O-Ring
45	94526	Spacer
46	94523	Inlet Adapter
47	94519	Muffler Assembly

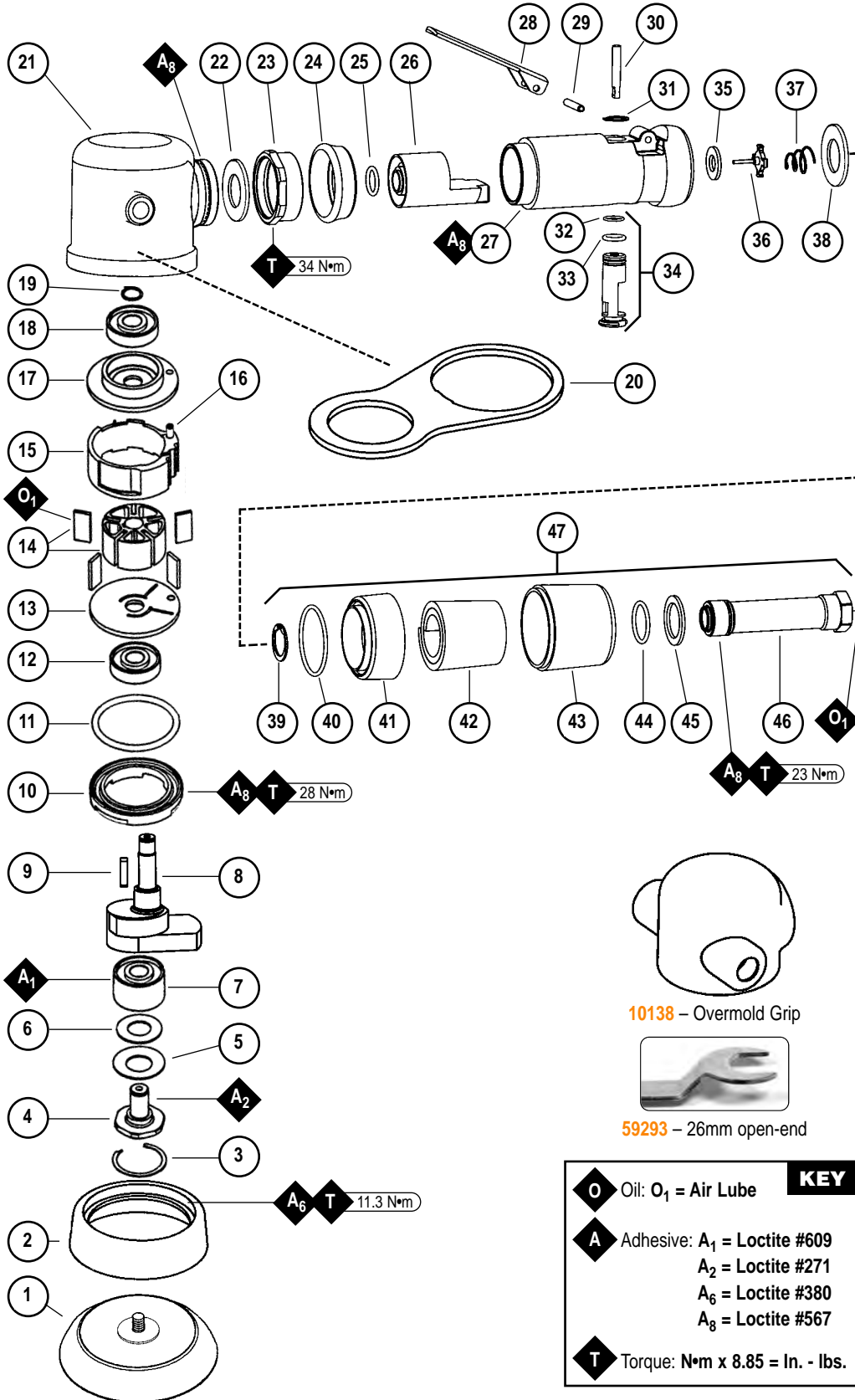

10138 - Overmold Grip



59293 - 26mm open-end

KEY	
	Oil: O ₁ = Air Lube
	Adhesive: A ₁ = Loctite #609 A ₂ = Loctite #271 A ₆ = Loctite #380 A ₈ = Loctite #567
	Torque: N•m x 8.85 = In. - lbs.

Important Operating, Maintenance and Safety Instructions

Carefully read all instructions before operating or servicing any Dynabrade® Abrasive Power Tool.

Warning: Hand, wrist and arm injury may result from repetitive work motion and overexposure to vibration.

Important: All Dynabrade rotary vane air tools must be used with a Filter-Regulator-Lubricator to maintain all warranties.

Operating Instructions:

Warning: Eye, face, sound, respiratory, and body protection must be worn while operating power tools. Failure to do so may result in serious injury or death. Follow safety procedures posted in workplace.

Caution: This tool is not to be run at free speed for any length of time. The tool is specifically designed to be low in vibration under load. Running the tool at free speed may cause the buffing pad to become dislodged from the back-up pad.

1. All initial set-up and maintenance to the tool should be done with the air line disconnected from the tool.
2. Install air fitting into inlet bushing of tool. The inlet bushing is a 1/4" NPT, for optimal performance of the tool, directly couple the air line to the tool or use a quick couple fitting with a large inlet hole such as Dynabrade's P/N **95675**. **Important:** Secure inlet bushing of tool with a wrench before attempting to install the air fitting to avoid damaging valve body housing.
3. While there may be other applications suited for this tool it has been specifically designed for the automotive market to be used as the second step of a special two step operation to remove paint imperfections in the clear coat of automotive finishes. It is imperative that the correct weight mated back-up pad be used with the tool to avoid excessive vibration. The tool is designed to use a Dynabrade P/N **56145** Pad; this pad has a mass of 27 grams.
4. A waffle pad such as 3M P/N **02648** is required to be attached to the back-up pad, other pads may be available contact a Dynabrade or 3M representative for additional information. Pre-condition a virgin pad thoroughly with 3M Final Finish Finesse-It Compound 3M P/N **82876** before attaching it to the tool. Once the pad has been conditioned this process need not be done until a new waffle pad is required either due to wear or the compound has been allowed to set up rendering the pad useless.
5. Apply a small (15mm) dab of Final Finish on the repaired area, and position tool on the repair surface. Apply approximately a 3 pound load on the pad before throttling the tool on. Adjust the force on the pad as required to feel the "sweet spot" (low vibration). Buffing for approximately 5 seconds with the pad flat on the work surface should remove the sand scratches of the initial process. Release the throttle lever and then remove the tool from the work piece.

Maintenance Instructions:

1. Through use of tool the mufflers may clog, hamper performance and require replacement.
2. Check tool speed regularly with a tachometer. A Magnetic Tachometer such as Dynabrade P/N **96368** is the simplest way to perform this operation. There are two test conditions to assure that the tool is running properly, these conditions being free speed and under load. The free speed is a simple check to quickly determine if the tool is out of specification. Checking under load requires additional test equipment but assures the proper operation of the tool. All speed testing must be done with 80 psig of air at the inlet bushing, a Pressure Gauge such as Dynabrade P/N **94315** is required. The tool should run between 9,000 RPM and 11,000 RPM free speed with 80 psig at the tool inlet bushing. If the tool is running outside these speeds it should be serviced to correct the cause before use. The under load condition can be checked by outfitting the tool with the proper back-up pad, waffle pad and buffing cream as outlined in the operating instructions. Apparatus is also required to monitor the load applied to the work surface. Dynabrade offers a Load Cell P/N **80025** that allows the tool to be tested on a bench. First zero out the scale by adjusting the knob on the side of the load cell to read zero when the tool, back-up pad, and waffle are resting on the wear plate of the load cell while connected to the air line. Apply a 3 pound load to the load cell and using the digital tachometer check the operating speed of the tool. The tool should be running 5,500 RPM minimum. If the tool is running outside this range it should be serviced to correct the cause before use.
3. All Dynabrade rotary vane air motors should be lubricated. Dynabrade recommends using Dynabrade Air Lube (P/N **95842**: 1 pt. 473 ml.) at a rate of 1 drop per minute. If Dynabrade Air Lube is not compatible with paint system it may be substituted with a compatible air tool lubricant with water absorbing properties to prevent internal components from rusting.
4. It is strongly recommended that all Dynabrade rotary vane air tools be used with a Filter-Regulator-Lubricator to minimize the possibility of misuse due to unclean air, wet air or insufficient lubrication. Dynabrade recommends the following: **10861** Air Line Filter-Regulator-Lubricator — Provides accurate air pressure regulation, two-stage filtration of water contaminants and micro-mist lubrication of pneumatic components.
5. Use only genuine Dynabrade replacement parts. To reorder replacement parts, please specify the **Model #**, **Serial #** and **RPM** of your machine.
6. A Motor Tune-Up Kit (P/N **96537**) is available which includes assorted parts to help maintain motor in peak operating condition.
7. Mineral spirits are recommended when cleaning the tool and parts. Do not clean tool or parts with any solvents or oils containing acids, esters, ketones, chlorinated hydrocarbons or nitro carbons.

Safety Instructions:

Products offered by Dynabrade should not be converted or otherwise altered from original design without expressed written consent from Dynabrade, Inc.



- **Important:** User of tool is responsible for following accepted safety codes such as those published by the American National Standards Institute (ANSI).
- Tool should not be running for extended periods of time free speed as it is not balanced for this condition. Avoid running the tool at free speed with a buffing pad installed onto the back-up pad as it may dislodge from the tool.
- Always disconnect the air line before changing the back-up pad or making machine adjustments.
- Inspect abrasives/accessories for damage or defects prior to installation on tools.
- Please refer to Dynabrade's Warning/Safety Operating Instructions Tag (Reorder No. **95903**) for more complete safety information.
- **Warning:** Hand, wrist and arm injury may result from repetitive work, motion and overexposure to vibration.

Notice

All Dynabrade motors use the highest quality parts and metals available and are machined to exacting tolerances. The failure of quality pneumatic motors can most often be traced to an unclean air supply or the lack of lubrication. Air pressure easily forces dirt or water contained in the air supply into motor bearings causing early failure. It often scores the cylinder walls and the rotor blades resulting in limited efficiency and power. Our warranty obligation is contingent upon proper use of our tools and cannot apply to equipment which has been subjected to misuse such as unclean air, wet air or a lack of lubrication during the use of this tool.

Lifetime Warranty

All Dynabrade portable pneumatic power tools are rigorously inspected and performance tested in our factory before shipping to our customers. If a Dynabrade tool develops a performance problem and an inherent defect is found during normal use and service, Dynabrade will warrant this tool against defects in workmanship and materials for the lifetime of the tool. Upon examination and review at our factory, Dynabrade shall confirm that the tool qualifies for warranty status, and will repair or replace the tool at no charge to the customer. Normally wearable parts and products are NOT covered under this warranty. Uncovered items include bearings, contact wheels, rotor blades, regulators, valve stems, levers, shrouds, guards, O-rings, seals, gaskets and other wearable parts. Dynabrade's warranty policy is contingent upon proper use of our tools in accordance with factory recommendations, instructions and safety practices. It shall not apply to equipment that has been subjected to misuse, negligence, accident or tampering in any way so as to affect its normal performance. To activate lifetime warranty, customer must register each tool at www.dynabrade.com. Dynabrade will not honor lifetime warranty on unregistered tools. A one-year warranty will be honored on all unregistered portable pneumatic power tools. Lifetime warranty applies only to portable pneumatic tools manufactured by Dynabrade, Inc. in the USA. Lifetime warranty applies only to the original tool owner; warranty is non-transferable.

Motor Assembly/Disassembly Instructions – 3" Dynabuffer

Important: Manufacturer's warranty is void if tool is disassembled before warranty expires.

Notice: All of the special repair tools referred to in these instructions can be ordered from Dynabrade. The 96525 Tool Repair Kit is available and the items contained in this kit are shown on the back of this parts page. Please refer to this parts page for proper part identification.

Motor Disassembly:

1. Disconnect the tool from the air supply.
2. Invert the tool and place the 57092 Repair Collar around the 02099 Housing and the 51361 Shroud, above the two handle bosses so that the back-up pad is facing up.
3. Use the 50679 Wrench (26mm) to remove the back-up pad.
4. Insert the 56058 Lock Ring Wrench into the tabs of the 56046 Lock Ring and loosen the lock ring from the 02099 Housing by turning it counterclockwise.
5. Remove the 51361 Shroud from the 02099 Housing by turning it counterclockwise. Using 57517 Torque Wrench (Sold Separately).
6. Pull the motor assembly out of the 02099 Housing and remove the 58357 Cylinder Seal.
7. Use retaining ring pliers to remove the 95626 Retaining Ring.
8. Fasten the 96346 Bearing Separator between the 51367 Bearing Plate and the 58358 Cylinder Assembly.
9. Place the motor assembly with the bearing separator attached, on the table of the 96232 Arbor Press (#2) so that the counter balance is pointing toward the floor.
10. Use a 3/16" dia. flat end drive punch as a press tool and push the 57422 Motor Shaft Balancer out of the 01206 Bearing.
11. Remove the rotor, vanes, and the 56047 Key from the motor shaft balancer.
12. Remove the 51366 Bearing Plate from the 57088 Bearing.
13. Fasten the bearing separator between the counter balance and the 57088 Bearing and use the arbor press to remove the bearing.
14. Secure the counter balance portion of the 57422 Motor Shaft Balancer in a vise with aluminum or bronze jaws so that the 26mm hex end of the 57069 Balancer Shaft is accessible and pointing up.
15. Use a small thin screwdriver to pick the notched end of the 95630 Snap Ring out of the motor shaft balancer. Work the screwdriver under and around the 95630 Snap Ring.
16. Fasten the bearing separator between the 26mm hex end of the 57069 Balancer Shaft and the 95628 Bearing Shield. Place the separator on the table of the arbor press so that the hex end of the balancer shaft is pointing toward the floor. Use a 5/16" dia. flat end punch as a press tool and press the 57069 Balancer Shaft out of the 56052 Bearing.

Motor Disassembly Complete.

Valve Disassembly:

1. Place the 52296 Repair Collar around the 10139 Housing and secure it in a vise so that the air inlet is pointing up.
2. Use two wrenches when removing the air fitting. Place one wrench on the 94523 Inlet Adapter to hold it stationary and use another wrench to remove the air fitting.
3. Remove the inlet adapter from the valve housing. **Note:** Refer to the exploded view of the muffler assembly to identify the parts and their order of assembly.
4. Use needle nose pliers to remove the 01468 Spring and the 01472 Tip Valve. The 01464 Seal can be removed from the valve housing with a small screwdriver.
5. Use retaining ring pliers to remove the 95558 Retaining Ring and push the 01469 Speed Regulator Assembly along with the 01449 Valve Stem out of the valve housing.
6. Use a 2.5mm dia. drive punch to remove the 12132 Pin and the throttle lever.

Valve Disassembly Complete.

Valve Assembly:

Important: Clean and inspect all parts before assembling.

1. Place the 52296 Repair Collar around the 10139 Housing and secure it in a vise so that the air inlet is pointing up.
2. Install the 01469 Speed Regulator Assembly (includes o-rings) into the valve housing and secure it in place with the 95558 Retaining Ring.
3. Insert the 01449 Valve Stem so that the end with the hole fits into the 01469 Speed Regulator Assembly.
4. Install the 01464 Seal into the inlet so that it is laying flat.
5. Use a needle nose pliers to grasp the white nylon portion of the 01472 Tip Valve and insert the metal pin of the tip valve into the hole of the 01449 Valve Stem.
6. Install the 01468 Spring so that the smaller end of the spring fits against the center of the tip valve.
7. Place the 01543 Air Control Ring against the air inlet opening of the 10139 Housing.
8. Install the 01468 Spring so that the smaller end of the spring fits against the center of the tip valve.
9. **Note:** Refer to the exploded view of the muffler assembly to identify the parts and their order of assembly. Apply a small amount of the Loctite #567 (or equivalent) to the threads of the inlet adapter and install it into the air inlet of the valve housing. (Torque to 23 N•m/200 in.-lbs.)
10. Install the throttle lever and secure it in place with the 12132 Pin.
11. Use two wrenches when installing the air fitting. Place one wrench on the 94523 Inlet Adapter to hold it stationary and use another wrench to install the air fitting.

Motor Assembly:

1. Place the hex end of the 57069 Balancer Shaft on the table of the 96232 Arbor Press (#2).
2. Install the 95628 Bearing Shield onto the balancer shaft so that the concave side is facing up.
3. Install the 56053 Bearing Seal onto the balancer shaft so that it fits down past the step on the balancer shaft.
4. Apply a small amount of the Loctite #271 (or equivalent) to the bearing surface of the balancer shaft.
5. Position the 56052 Bearing Press Tool to press the bearing down to the step of the 57069 Balancer Shaft.
6. Apply a small amount of Loctite #609 (or equivalent) to the outer diameter of the 56052 Bearing and install the balancer bearing assembly into the 57422 Motor Shaft Balancer.
7. **Important:** To avoid injury it is best to hold the counter balance in a vise when the 95630 Snap Ring is being installed. Use a small thin screwdriver to install the snap ring. Install the 95630 Snap Ring between the hex end of the balancer shaft and the 95628 Bearing Shield. The snap ring must fit into the groove in the motor shaft balancer.
8. Use the larger end of the 57091 Bearing Press Tool to press the 57088 Bearing down to the top of the counter weight of the 57422 Motor Shaft Balancer. Also install the 51366 Bearing Plate in the same manner. (continued on next page)

Drawing 1

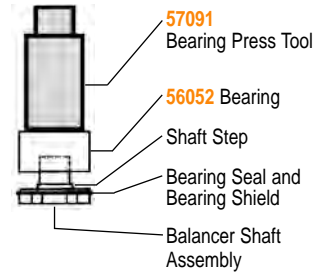

Drawing 2

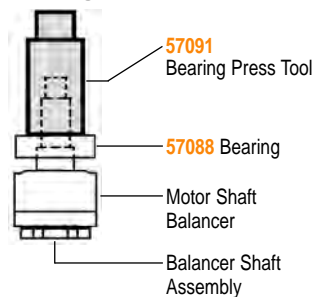

Drawing 3

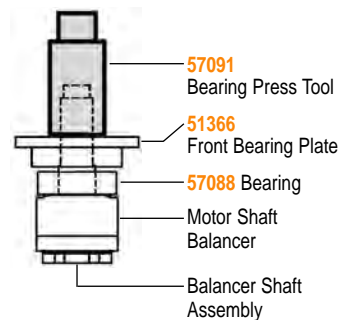

Drawing 4

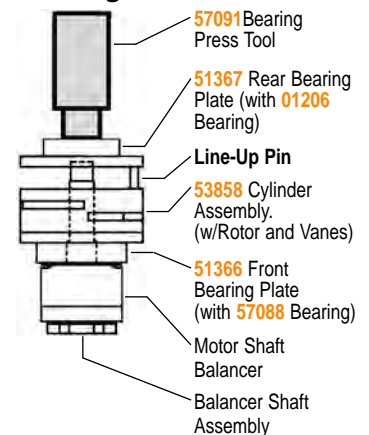

Motor Assembly/Disassembly Instructions – 3" Dynabuffer (continued)

9. Install the **56047** Key into the **57422** Motor Shaft Balancer.
10. Install the **57113** Rotor/Blade Set (5/pkg.). Apply the **95842** Dynabrade Air Lube (10W/NR or equivalent) to the vanes.
11. Position the **58358** Cylinder Assembly so that the short line-up pin side fits against the **51366** Bearing Plate.
12. Install the **51367** Bearing Plate and the **01206** Bearing onto the **57422** Motor Shaft Balancer. **Note:** The **01206** Bearing is a slip fit into the **51367** Bearing Plate. Use the smaller end of the **57091** Bearing Press Tool to press the bearing/plate down only until the **51367** Bearing Plate comes in contact with the **58358** Cylinder Assembly. This should create a snug fit between the bearing plates and the cylinder.
13. Install the **95626** Retaining Ring with retaining ring pliers so that the curve of the ring is arched up. Press the ring down into the groove at the top of the motor shaft balancer.
14. Install the **56046** Lock Ring with the **50659** O-Ring over the counter balance of the motor shaft balancer so that the o-ring fits against the **51366** Bearing Plate. Apply a small amount of the Loctite #567 (or equivalent) to the threads of the lock ring.
15. Apply the **95842** Dynabrade Air Lube (10W/NR or equivalent) to the **58357** Cylinder Seal and install it into the side of the cylinder.
16. Carefully install the motor assembly into the **02099** Housing so that the **98462** Pin fits into the line-up hole on the inside of the housing. **Note:** Grasp the motor assembly by the counter balance while applying pressure against the **56046** Lock Ring with the tips of your thumb and index finger. Align the **98462** Pin with the hole on the inside of the **02099** housing and carefully insert the air motor into the housing until the lock ring comes in contact with the internal threads of the **02099** Housing. Using your finger tips, turn the lock ring clockwise into the housing. If resistance is felt, stop and realign the motor assembly. If the motor assembly is aligned correctly the lock ring and the motor should advance into the housing easily. Before the lock ring and motor are tightened all the way into the housing, fit the **51361** Shroud over the counter balance and thread the shroud onto the external threads of the **02099** Housing. Use the **56058** Lock Ring Tool to thread the **56046** Lock Ring into the **02099** Housing. Use the **57092** Repair Collar to hold the **02099** Housing in a vise when securing the lock ring. (Torque to 28 N•m/250 in.- lbs.)
17. Add 2-3 drops of Loctite #380 (or equivalent) to the male thread of housing. Install **51361** Shroud (Torque to 11.3 N•m/100 in.- lbs.) using **57517** Torque Wrench (Sold Separately).

Motor Assembly Complete. Tool Assembly Complete.

Throttle Positioning Procedure:

1. Place the **52296** Repair Collar around the valve housing and secure it in a vise so that the **02099** Housing is pointing up.
2. Slip the **01547** Collar down onto the valve housing to expose the **01461** Lock Nut.
3. With a firm hold on the **02099** Housing, use a 34mm or an adjustable wrench to turn the **01461** Lock Nut counterclockwise to loosen the **02099** Housing from the valve housing.
4. Orient the throttle lever to the operators desired grip and positioning. **Note:** Allow for additional rotation of the **02099** Housing as the **01461** Lock Nut is tightened.
5. With a firm hold on the **02099** Housing to reduce its rotation, use a 34mm or an adjustable wrench to tighten the **01461** Lock Nut. (Torque to 45 N•m/400 in.- lbs.)

Important: Carefully perform this procedure so as not to entirely separate the 02099 Housing from the valve housing. Loosen the 01461 Lock Nut only enough to make the desired throttle lever adjustment.

Note: Motor should operate at between 9,000 and 11,000 RPM free speed with 80 PSIG of air at the inlet of the tool. RPM should be checked with a tachometer. Before operating, we recommend that 2-3 drops of Dynabrade Air Lube P/N **95842** (or equivalent) be placed directly into the air inlet with throttle lever depressed. Operate the machine for approximately 30 seconds before application to workpiece to determine if machine is working properly and safely and to allow lubricating oils to properly dispense through machine. Loctite® is a registered trademark of the Loctite Corp.

Disc pad Change:

1. Insert **50679** Wrench on flats of **57069** Balancer Shaft and twist off sanding pad by hand.
2. With wrench still in place, hand tighten new pad on tool.
3. No need to remove shroud.

Model Number	Motor hp (W)	Motor RPM	Sound Level	Maximum Air Flow SCFM (LPM)	Air Pressure PSIG (Bars)	Spindle Thread	Weight Pound (kg)	Length Inch (mm)	Height Inch (mm)
10127	.2 (149)	10,000	74 dB(A)	23 (651)	80 (5.5)	5/16"-24 female	2.0 (.91)	8-5/16 (211)	3-3/4 (96)

Additional Specifications: Air Inlet Thread 1/4" NPT • Hose I.D. Size 3/8" or 10mm • Tool Vibration Data (Per ISO 8662.8) 2.0 M/s²

Optional Accessories



80030 Training and Maintenance Test Equipment Kit:

- **80025** Load Cell measures tool RPM under load and useful for training operators for proper buffing pressure/operation. Electronic tachometer pick-up securely fastens to wear plate.
- **94315** Pressure Gauge to ensure peak operating performance.
- **95842** Air Lube formulated for pneumatic tools. Prevents rust and formation of gum/sludge for longer tool operation with greater power and less downtime.
- **96368** Tachometer used to measure tool RPM.



Filter-Regulator-Lubricator 10681: 55 SCFM @ 100 PSIG

- Provides accurate air pressure regulation, two stage filtration of water/contaminants and lubrication of pneumatic components.



96537 Motor Tune-Up Kit

- Includes assorted parts to help maintain and repair motor.

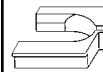

57092 Repair Collar

- Specially designed collar for use in vise to prevent damage to motor housing during disassembly/assembly.



52296 Repair Collar

- Specially designed collar for use in vise to prevent damage to valve body during disassembly/assembly.

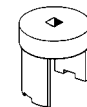

56058 Lock Ring Wrench

- Lock Ring Tool has a 3/8 in. square socket for use with 3/8 in. drive; breaker bar, ratchet head, or torque wrenches.



57091 Bearing Press Tool

- Use with a #2 arbor press to achieve accurate press of bearings and motor parts.

96525 Tool Repair Kit

- Includes special tools for proper disassembly/assembly of the tool.
- Includes all above listed tools.



Visit Our Web Site: www.dynabrade.com

Email: Customer.Service@Dynabrade.com

DYNABRADE, INC., 8989 Sheridan Drive • Clarence, NY 14031-1490 • Phone: (716) 631-0100 • Fax: 716-631-2073 • International Fax: 716-631-2524
DYNABRADE EUROPE S.à.r.l., Zone Artisanale • L-5485 Wormeldange—Haut, Luxembourg • Telephone: 352 76 84 94 1 • Fax: 352 76 84 95 1

© DYNABRADE, INC., 2007

PRINTED IN USA

APD07.05_08/07