

Raptor Vac™ Conductive

Dry, Electric Portable Vacuum Systems

Model	Voltage/ Frequency	Region (Plug)	Capacity Gallon (Liter)
61401	120/60 Hz	US/Canada	20 (78)
61403	230/50 Hz	UK	20 (78)
61409	230/50 Hz	CEE7	20 (78)
61413	230/50 Hz	Switzerland	20 (78)



“M” CLASS DRY VACUUM

When employed in accordance with their intended use, the industrial vacuum cleaners described in these operating instructions are suitable for picking up non-flammable, dry dusts. They correspond to dust class “M” in accordance to: EN 60335-2-69. By SLG, Germany



**ONLY FOR US AND CANADA MARKET
SEULEMENT POUR LES MARCHÉS US ET CANADA**



**DRY VACUUM CLEANERS
INDOOR USE ONLY**

INSTRUCTION MANUAL

Vacuum Head

Complete Assembly

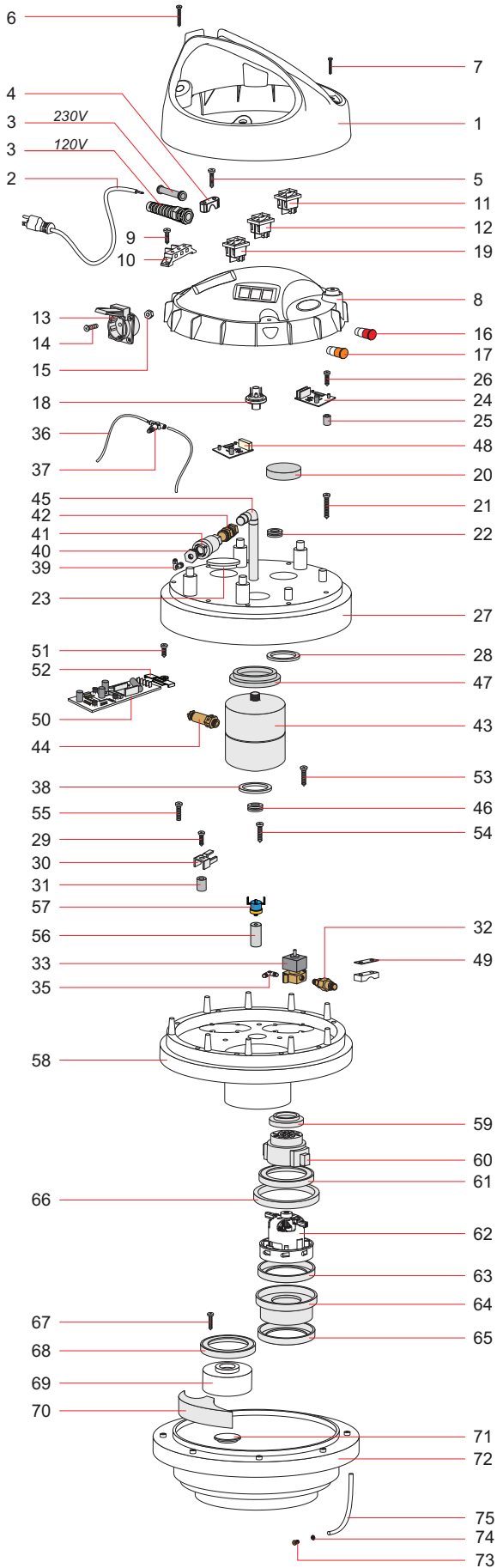

ITEM	DESCRIPTION	P/N
1	Handle – 120 V	80460
	Handle – 230 V	80464
2	Cord – 120 V	80440
	Cord – 230 V	80485
3	Strain Relief – 120 V	80495
	Strain Relief – 230 V	80486
4	Clamp – 120 V	N/A
	Clamp – 230 V	80258
5	Screw	80235
6	Screw	80414
7	Screw	80232
8	Cover, Top	80461
9	Screw	80402
10	Terminal Board – 120 V	80415
	Terminal Board – 230 V	80487
11	Switch On/Off	80475
12	Switch Tool Select	80450
13	Socket – 120 V, US/Canada	80488
	Socket – 230 V, UK	80492
	Socket – 230 V, CEE7	80493
	Socket – 230 V, Switzerland	80494
14	Screw	80423
15	Nut	80406
16	Lamp, Red	80477
17	Lamp, Orange	80451
18	Pressure Sensor	80425
19	Switch Pocket Cover	80428
20	Filter Bracket	80419
21	Screw	80414
22	Guide	80405
23	Cover Cap	80284
24	Electric Card - 2 Speed – 120 V	80468
	Electric Card - 2 Speed – 230 V	80489
25	Sleeve	80472
26	Screw	80232
27	Cover, Bottom	80467
28	Washer	80420
29	Screw	80418
30	Clamp	80173
31	Sleeve	80473
32	Check Valve	80446
33	Electrovalve – 120 V	80458
	Electrovalve – 230 V	80490
34	Connector	80449
35	Elbow	80447
36	Tube (per Meter)	80401
37	Pressure Reducer	80439
38	Washer	80420
39	Elbow	80447
40	Reducer	80434
41	Valve	80436
42	Connector	80435
43	Air Tank	80432
44	Safety Valve	80437
45	Tube	80438
46	Guide	80405
47	Gasket	80448
48	Electronic Card	80445
49	Bracket	80245
50	Electronic Card	80430
51	Screw	80235
52	Bracket	80172
53	Screw	80255
54	Screw	80255
55	Screw	80413
56	Heat Sensor	80452
57	Thermoregulator	80422
58	Motor Mount	80478
59	Ring	80470
60	Cap	80442
61	Gasket	80290
62	Motor – 120 V	80462
	Motor – 230 V	80491
63	Gasket	80426
64	Spacer	80443
65	Gasket	80290
66	Filter	80441
67	Screw	80235
68	Gasket	80290
69	Plug	80471
70	Muffler	80416
71	Cap	80417
72	Base	80469
73	Nipple	80298
74	Washer	80170
75	Tube	80171

Pneumatic Tool Supply Line

Complete Assembly

ITEM	DESCRIPTION	P/N
1	Nipple	80429
2	Fitting	80229
3	Guide	80421
4	Bracket	80231
5	Screw	80225
6	T Connector	80433
7	Nipple	80400
8	Sensor Body	80476
9	Sensor Plate	80227
10	Sensor	80241
11	O-Ring	80226
12	Screw	80228
13	Nipple	80220
14	Washer	80221
15	Y Connector	96571
16	Tube (per Meter)	80453
17	Coupling	80222
18	Guide	80421
19	Bracket	80231
20	Screw	80225

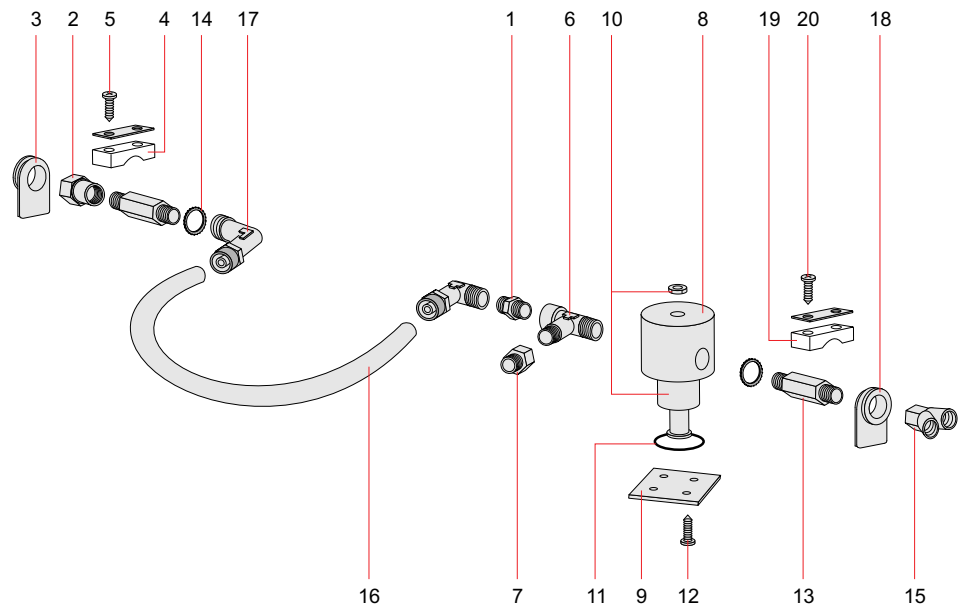

Filter

Complete Assembly

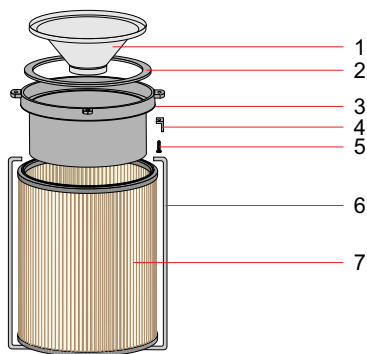

ITEM	DESCRIPTION	P/N
1	Diffuser	80444
2	Gasket	80234
3	Cartridge Support	80479
4	Filter Support	80457
5	Screw	80243
6	Locking Staff	80431
7	HEPA Filter	80459

Tank/Cart

Complete Assembly

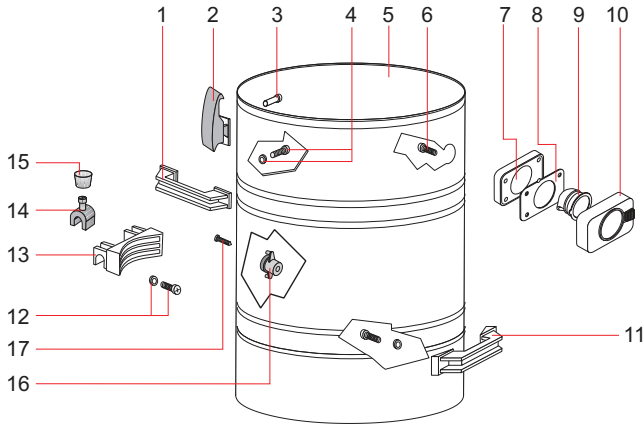

ITEM	DESCRIPTION	P/N
1	Handle	80081
2	Hook	80430
3	Rivet	80246
4	Seal/Screw	80073
5	Tank	80279
6	Screw	80169
7	Gasket	80163
8	Gasket	80164
9	Deflector	80165
10	Vac Inlet (Orange Button)	80466
11	Handle	80081
12	Seal/Screw	80073
13	Hinge Body	80071
14	Hinge Clasp	80072
15	Hinge Knob	80075
16	Valve	80266
17	Screw	80267

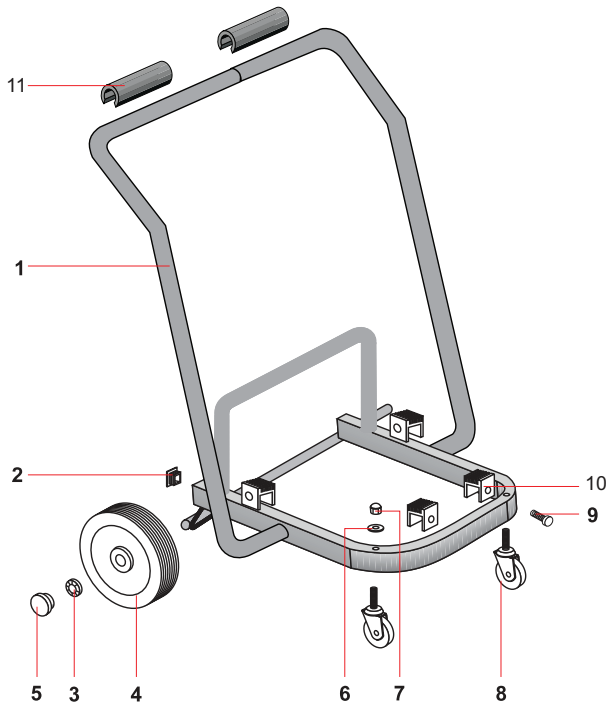

ITEM	DESCRIPTION	P/N
1	Frame	80269
2	Cap	80270
3	Retainer	80062
4	Wheel	80061
5	Axle Cap	80063
6	Washer	80080
7	Nut	80079
8	Caster	80078
9	Screw	80225
10	Foot	80271
11	Handle Grip	80272

WARNING - An external air supply source connected to the vacuum cleaner shall not exceed the Max Pressure of **150 PSI**.

COAXIAL VACUUM HOSE ASSEMBLY – PART NO. 31962 1-1/4" DIA. X 20' (32 MM X 6M)

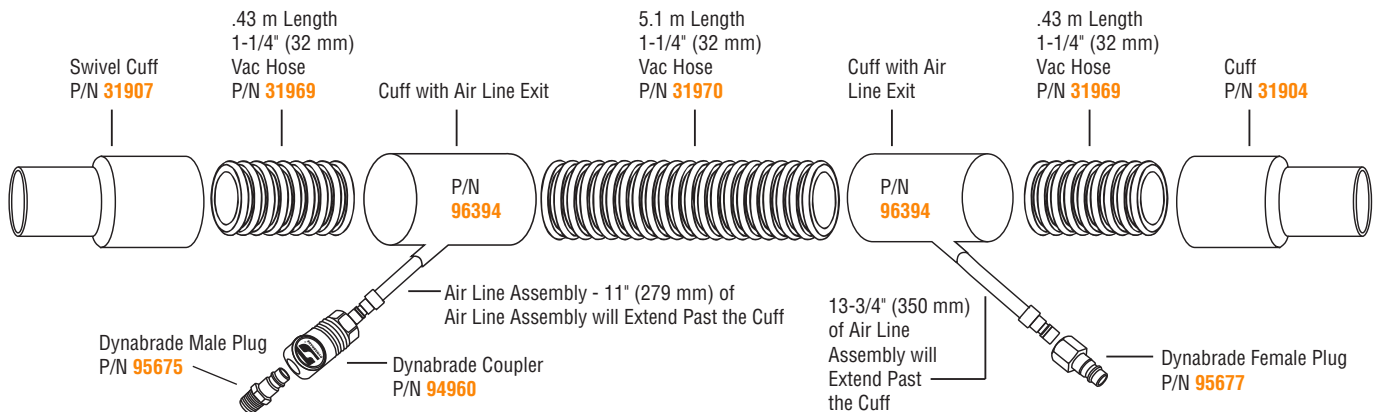

IMPORTANT SAFETY INSTRUCTIONS

When using an electrical appliance, basic precautions should always be followed, including the following:

READ ALL INSTRUCTIONS BEFORE USING

WARNING - To reduce the risk of fire, electric shock, or injury:

- 1 - Do not leave appliance when plugged in. Unplug from outlet when not in use and before servicing.
- 2 - Do not expose to rain. Store indoors.
- 3 - Do not allow to be used as a toy. Close attention in necessary when used by or near children.
- 4 - Use only as described in this manual. Use only manufacturer's recommended attachments.
- 5 - Do not use with damaged cord or plug. If appliance is not working as it should, has been dropped, damaged, left outdoors, or dropped into water, return it to a service centre.
- 6 - Do not pull or carry by cord, use cord as a handle, close a door on cord, or pull cord around sharp edges or corners. Do not run appliance over cord. Keep cord away from heated surfaces.
- 7 - Do not unplug by pulling on cord. To unplug, grasp the plug, not the cord.
- 8 - Do not handle plug or appliance with wet hands.
- 9 - Do not put any objet into openings. Do not use with any opening blocked; keep free of dust, lint, hair and anything that may reduce air flow.
- 10 - Keep hair, loose clothing, fingers and all parts of body away from openings an moving parts.
- 11 - Do not pick up anything that is burning or smoking, such as cigarettes, matches or hot ashes.
- 12 - Do not use without dust bag and/or filters in place.
- 13 - Turn off all controls before unplugging.
- 14 - Use extra care when cleaning on stairs.
- 15 - Do not use to pick up flammable or combustible liquids such as gasoline or use in areas where they may be present.
- 16 - "Connect to a properly grounded outlet only. See Grounding Instructions".
- 17 - Use only original spare parts.

After finishing work:

- 1 - Switch off the cleaner and unplug the power cord
- 2 - Wind up the mains lead
- 3 - Empty dirt tank
- 4 - Clean the vacuum cleaner inside and outside by suction and wiping
- 5 - Store the machine indoors in clean, dry place
- 6 - This appliance is provided with an automatically reset thermal limiter to avoid damage to the motor.

SAVE THESE INSTRUCTIONS

INSTRUCTIONS TO BE STRICTLY FOLLOWED

- Components used in packaging (i.e. plastic bags) can be dangerous: keep away from children and animals.
- **ATTENTION:** this machine can only be used to suction dry substances and cannot be utilized outdoor with rainy weather .
- The use of this machine for anything not specified in this manual may be dangerous and must be avoided.
- The suction nozzle should be kept away from the body, especially from delicate areas such as eyes, ears and mouth.
- The equipment should be correctly assembled before use.
- Ensure that power socket used is correct for the machine plug.
- Check the voltage indicated on the rating plate is the same as the supply voltage.
- **WARNING:** these machines are not designed for picking up health endangering dusts (i.e. fireplace ash) or inflammable/explosive substances.
- Never leave the equipment unattended while in use.
- Never use this equipment to pick up any kind of liquids.
- Always remove the plug from the socket before carrying out any operation with the machine or whenever the machine remains unattended or can be handled by children or people not conscious of their actions.
- The main supply cable should not be used to pull or lift the machine.
- Never immerse the machine in water for cleaning nor use pressure water jets to wash it.
- Should the line cable be damaged, this must be either replaced by the manufacturer or by its service centre or in any case by a person having similar skills, so as to prevent any risk.
- If you use extension cables make sure they are placed on dry surfaces and protected from eventual water jets.
- This equipment should not be used to pick up water from containers, sinks, tubs, etc.
- Service and repairs must be carried out by qualified personnel only. Replacement parts for the machine must be original spare parts only.
- The manufacturer cannot be held responsible for any damage/injury caused to persons or property, because of the incorrect use of the machine due to procedures being used which are not specified in this instruction manual.

GROUNDING INSTRUCTIONS

This appliance must be grounded. If it should malfunction or breakdown, grounding provides a path of least resistance for electric current to reduce the risk of electric shock. This appliance is equipped with a cord having an equipment-grounding conductor and grounding plug. The plug must be inserted into an appropriate outlet that is properly installed and grounded in accordance with all local codes and ordinances.

WARNING - Improper connection of the equipment-grounding conductor can result in a risk of electric shock. Check with a qualified electrician or service person if you are in doubt as to whether the outlet is properly grounded. Do not modify the plug provided with the appliance - if it will not fit the outlet, have a proper outlet installed by a qualified electrician.

This appliance is for use on a nominal 120-Volt circuit and has a grounding attachment plug that looks like the plug illustrated in sketch (A).

Make sure that the appliance is connected to an outlet having the same configuration as the plug. No adaptor should be used with this appliance.

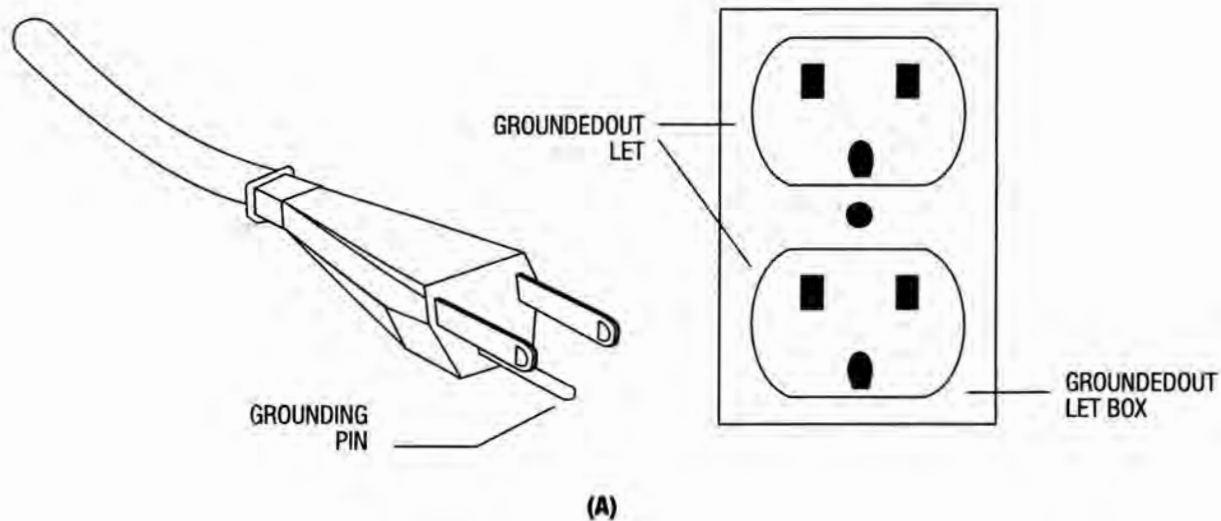

GROUNDING INSTRUCTIONS

This unit must be grounded. If it should malfunction or breakdown, grounding provides a path of least resistance for electric current to reduce the risk of electric shock.

Where it is critical to avoid shocks or sparks caused by static electricity, an electrically conductive and grounded air supply hose must be used.

WARNING

Grounding by means of a ground wire between both ends of the air supply tubing passing through vacuum hose is recommended.

ASSEMBLY INSTRUCTIONS

Refer to the drawing and parts list for the name and location of parts.

1. While opening the carton, carefully inspect outside of the carton for any sign of transportation damage, and if so, notify your shipper immediately.
2. Open carton and remove hoses, hose connectors and other accessories.
3. Lay carton on its back and wheel the unit out.
4. Remove all packing, release the unit and remove Motorhead/Vacuum Head Assembly to make sure no packing materials are left inside the unit.
5. Check to make sure the filter is seated firmly. If not, tighten at base of filter unit.
7. Remove the vacuum hose assembly. Note that the air supply tube (the smaller of the two) protrudes at both ends and is longer than the vacuum hose.
8. Connect quick coupler male end to air outlets located on vacuum head assembly.
9. Insert vacuum hoses.
10. Connect air supply to air inlet fitting (3/8" NPT female threads) located at the back side of Motorhead. Air pressure should be adjusted according to the pressure requirement of the air tools you are using. Do not exceed 150 PSIG (10.3 kg/cm²). Some pressure drop is unavoidable between the main air supply and the air tools due to internal flow resistance in a long air hose.

A 1/2" INTERNAL DIAMETER SUPPLY AIR LINE is recommended. Set regulator by installing an in-line pressure gage (Part No. 94315) at the inlet of the air tool being used. Run the tool and adjust regulator such that there is 90 PSIG @ the tool inlet.

The installation of a Dynabrade Filter-Regulator-Lubricator (FRL Part No. 11411) is highly recommended to protect the unit and the air tools.

Where it is critical to avoid shocks or sparks caused by static electricity, an air supply hose which is electrically conductive and ground must be used.

11. All Dynabrade Vacuum Models come with a sample dust bag. Install bag inside main body. Make sure that vacuum connection tube protrudes through the hole in the bag.
12. Order dust bags (Part No. 64682) before you run out of them.
13. Return Motorhead/Vacuum Head Assembly to the unit and lock the two rim clamps to secure Motorhead/Vacuum Head Assembly in position.
14. Connect your Dynabrade air tool or accessory and you are now ready for working with the Dynabrade Portable Vacuum System.

CAUTION

THIS IS A PRECISION PIECE OF EQUIPMENT designed for dust extraction to keep your ENVIRONMENT and your REPUTATION "DUST-FREE." Read operating instructions before using Dynabrade Portable Vacuum System and be thoroughly conversant with safety precautions in your locality.

OPERATING INSTRUCTIONS

The following items should be well-noted for the effective use of the unit.

1. Always wear safety glasses and any other safety items required by law.
2. The vacuum system will operate by an on/auto/manual switch located on the front of the Motorhead/Vacuum Head Assembly. This switch must be turned on to activate the Motorhead.
3. **VACUUM SPEED CONTROL:** Unit is equipped with a one tool or two tool speed setting.
4. **ELECTRONIC THERMAL PROTECTION DEVICE:** Unit is equipped with a overload prevention system. If this feature is activated a **20 MIN. COOL DOWN PERIOD** inhibits use. After a

complete 20 min. cool down period has passed the Electronic Thermal Protection Device will **RE-SET** automatically and the unit will be on line ready for use.

5. **VISUAL WARNING SIGNAL:** Unit is equipped with a visual warning (yellow) light to indicate when air velocity falls below 20m/s. Turn off vacuum and replace disposable collection bag. The warning signal will **RE-SET** automatically and the unit will be ready for use.

OPERATING TIPS AND TROUBLESHOOTING

Keep machine clean to ensure optimum performance. After each use, lift off vacuum head and knock dust from filter. After one hour of continuous use, lift out the Motorhead/Vacuum Head Assembly and check the amount of dust accumulated in the unit. Remove the dust bag if necessary and replace with a new one. We recommend a soft brush to clean the filter. **DO NOT USE A BLOW GUN.**

Decrease in Vacuum Performance

1. Clean the filter thoroughly and as often as necessary. The filter used inside is water resistant and washable. To prevent damage, do not use high pressure or solvent to wash the filter.

2. If the filter (P/N 80459) should become damaged or badly clogged and cannot be cleaned, replace with a new one.
3. Check all the vacuum lines for blockage or leakage.

Vacuum Stops During Use

1. This vacuum is equipped with a Electronic Thermal Protection Device. If the vacuum stops and the red indicator light appears ON, the unit has shut down as a result of increased temperature. Once the unit has regained a temperature that is allowable for operation the vacuum will resume operation.

REMOVAL/INSTALLATION OF MOTORHEAD FROM MAIN ASSEMBLY

If the filter element becomes clogged or to clean the inner portions of the drum (canister) the Motorhead Assembly must then be removed to perform cleaning. When removal becomes necessary for cleaning or other service, follow the procedures described below.

Removal

1. Unplug the unit before attempting service or maintenance work.
2. Remove Top Lid by unlatching (2) hinges.

3. Use a conventional vacuum cleaner to clean entire inside of Motorhead/Vacuum Head Assembly and drum (canister).

Upon completion of the service work, install top lid according to the following procedure:

Installation

1. Place cleaned unit onto the drum (canister) and latch (2) hinges to properly attach the lid. Unit is now ready for operation.

TILT-N-CLEAN OPERATION INSTRUCTION

Unit has a Tilt-n-Clean feature to aid in overall functionality of the work equipment and work environment:

1. Unplug the unit before attempting service or maintenance work.
2. Unclamp and remove Motorhead/Vacuum Head Assembly. Drum (canister) is now able to be tilted backwards and emptied. Dispose of debris properly.

3. Or, Pull side release hinges away from the drum (canister) and remove the entire drum (canister) from the trolley. With drum (canister) removed dispose of debris properly.

ORIGINAL INSTRUCTION

IT IS RECOMMENDED TO KEEP THIS MANUAL ALWAYS ON HAND FOR FUTURE REFERENCES.

WARNING: PLEASE READ CAREFULLY THE INSTRUCTION MANUAL BEFORE USING.

Dry vacuum cleaner

Certified to vacuum class “M” dusts - According to Regulation EN 60335-2-69 annex AA



the CE mark “European Compliance” means that the product is in accordance with the essential requirements provided by the law, concerning safety and public health measures, protection of the consumer, etc.



M FILTRATION: MEDIUM HAZARD

for separating all dusts with all limit values of occupational exposure not less than 0.1 mg/m³



Symbol of hazardous dust collection



WARNING: These symbols will be used to remind the operator to pay attention to operations that may cause lesions, including death, to the operator or to other people or animals nearby. Furthermore, the operations indicated by these symbols may cause damages, even irreparable ones, to the suction device.

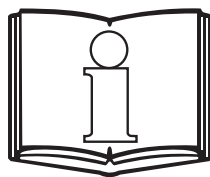

ATTENTION: Please read carefully the instruction manual before using. it is recommended to keep this manual for future references.



Do not dispose of power tools into household waste!
According to the European Directive 2012/19/UE on waste electrical and electronic equipment (WEEE) and its incorporation into national law, power tools that are no longer suitable for use must be separately collected and sent for recovery in an environmental- friendly manner.



INDICATIONS TO BE STRICTLY ADHERED TO

- This vacuum cannot be used by children, by people with reduced physical, sensorial or mental capacities or without any experience and knowledge, unless they did not receive instructions relative to the use of the appliance and are controlled by a person responsible for their safety
- Children should be controlled so that they don't play with the appliance.
- The packaging components could constitute potential dangers (as for example plastic bags): they must be kept away from children's reach and from other people or animal not conscious of their actions.
- To correctly dispose of the packaging follow the local standards in force.



Any different use from that indicated in this manual could constitute a danger, therefore, it must be avoided.

- WARNING: Operators must be properly trained for using these machines.
- WARNING: Only for indoor application.
- WARNING: This appliance must be stored, taking its weight into consideration, on a solid, steady, safe and not sloping plane, indoor and in moisture free environments.
- WARNING: This appliance can be used for suction dry only, and it cannot be stored in the open or under damp conditions.
- WARNING: Do not vacuum liquids.
- WARNING: Don't ever point the suction towards delicate parts of the body – of people or animals - such as eyes, ears, mouth, etc.
- WARNING: If the appliance is provided with a supplementary socket, do not exceed the power reported on the socket. Non-observance may cause fires and damages even lethal to the user.
- WARNING: The appliance is not suitable for areas protected against electrostatic discharges.
- WARNING: Make sure that the power cable is totally unrolled before you start using the vacuum.



- **WARNING:** Use only the accessories supplied with the appliance or those specified in the instruction manual. Using other accessories might compromise the operator safety.
- **WARNING:** Do not leave the unsupervised a working machine. Always remove the plug from the socket if the appliance is not working, and store it away from the reach of children or people who are not conscious of their own actions.
- **WARNING:** When using electric tools do not exceed the power reported on the additional socket. Make sure that the line voltage of the electric hand tool coincide with that reported on the label of technical data. Non-observance of this rule may cause fires and damages even lethal to the user.
- **WARNING:** This appliance is not suitable to pick up toxic, explosive, flammable or incandescent substances. The maximum temperature allowed is 40°C / 104°F.
- Every part of the appliance must be correctly assembled before using it. Verify, furthermore, that the filtering elements have been correctly and efficiently assembled.
- The appliance must be operated, installed, repaired and handled on a steady, safe and not sloping plane.
- Make sure that the values indicated on the technical data label correspond to those of the network to which you intend to connect the appliance and that the socket is compatible with the plug.
- Do not pick up materials that can damage the filtering elements (such as glass, metal etc.).



- Do not ever pull or lift the appliance through the electrical cable.
- Don't touch the plug or the appliance with wet hands.
- Do not immerse the vacuum into water, neither use water jets to clean it.
- Always remove the plug from the socket before performing any maintenance work.
- Regularly control the feeding cable looking for damages, cracks or ageing. Replace the cable if necessary.
- Specialized personnel must always carry out maintenance and repairs; any damaged part must be replaced with original spare parts.
- **WARNING:** It is forbidden to carry out changes to the appliance. Tampering could cause fires and damages even lethal to the user and could make warranty no more effective.
- The manufacturer declines any responsibility for damages caused to people or things due to non-compliance of these instructions or if the appliance is not properly used. The operator that use the vacuum cleaner equipped with an essential filter must be an authorized person and must be aware of the risks resulting from the vacuuming of toxic substances.

WARNING: This vacuum is equipped with a manostat with a control led that lights when the cartridge filter (essential filter) is clogged and must be replaced.

Do not clean the essential filter with air.

The essential filter must be disposed of after use. This is necessary in order not to compromise the efficiency of the filtering system which would let go unwanted dust particles into the environment.

- To guarantee a safe and sustained functioning of the machine, do periodically the routine maintenance, checking the integrity of plastic parts and technical issues, concerning filtrating efficiency and the correct operating of the main control system.
- Regularly control the power cable looking for damages, cracks or ageing. If the cable is damaged replace it.
- The substitution of the damaged cable must be done by the tech assistance service or by competent authorized personnel with recognized qualification
- When using electrical extension cord, make sure that it is compatible with the power cable and that it is not in contact with liquids or conductive surfaces
- Check that the machine is equipped with all the safety devices and their efficiency.
- Before sending the vacuum to technical assistance, it must be cleaned outside and inside the tank, removing the filtering system if contaminated, just to prevent risks to maintenance men.
- Before any operation prepare all the appropriate measures for one's personal safety, for the safety of others and of the surrounding environment (refer to the safety procedures in the work place).
- All the parts of the device must be deemed to be contaminated when they are removed from the area of use and appropriate action must be taken to prevent dispersal of dust.
- When maintenance or repair operations are carried out, all contaminated elements which cannot be cleaned well must be eliminated.
- These elements must be eliminated in impenetrable bags conforming to the regulations applicable for the elimination of such materials.
- It is necessary to supply a proper exchange of air in the room if the exhaust air of the device returns into the room. Reference to national regulations is necessary.
- The dusts on the essential filter are or could be toxic, therefore we suggest that instruments for personal protection be used: use gloves, protective mask for nose and mouth, protective glasses and a full overall to prevent contaminated dust from making contact with other parts of the operator's body.
- Use a container suitable for disposal.
- The advice mentioned is the minimum safety requirement to be adopted. Please take note of the safety regulations in the work place.
- It is recommended to wait a few minutes (after turning off the vacuum cleaner) before removing the essential filter so that any contaminated powder be allowed to settle inside the tank.

- The dirty essential filter is toxic waste and must be treated as such.
- For the disposal thereof please adopt the procedures recommended by the relevant laws in force applied at the place of use.
- It is advisable to immediately place the dirty essential filter, dismantled from the vacuum cleaner, into the appropriate container for disposal.
- The user can clean the machine only with a dry cloth.

NOISE LEVEL: Values measured according to EN 60704 - 1 (1997) / EN 60704 -2 - 1 (2001) rules. Measurement A for the sound pressure level of the machine is = 73,2 dB (A) Under unfavorable power conditions, the appliance may cause temporary drops in voltage

VIBRATION: The value of the hand-arm vibration on the suction pipe is less than 2,5m/s² as recommended by ISO 5349-1

MOTOR PERFORMANCES:

Nominal power 1250W max

Maximum vacuum 251 hPa

Maximum air flow 238 m³/h

COMPONENTS AND FEATURES

Description of electro/pneumatic controls

(B) BLACK ELECTRIC SWITCH (I O II)

(select different working modes)

MODE "0": machine is off

MODE "I": the motors are working with cyclic cleaning of the cartridge filter

MODE "II": electro/pneumatic telecontrol system is in automatic mode and the cleaning of the cartridge filter are working.

Vacuum cleaner engine turns on or off automatically depending on whether or not the following accessories are on or off:

- 1- the electro-tool connected to the supplementary socket (max W see label on the plug "S")
- 2- the air tool connected to the compressed air socket (V1).

To connect the electro tool the maximum power (W max) achievable is printed on the label placed on socket's flap.

When the tool is switched off, after about 8" the vacuum cleaner motor will switch off.

IMPORTANT INFORMATION WHEN CONNECTING ELECTRO/PNEUMATIC TOOLS TO THE VACUUM CLEANER

WARNING: The manufacturer is not responsible for damages to people or things due to an incorrect or negligent use of the ELECTRIC REMOTE CONTROL DEVICE.

WARNING: THE ADDITIONAL SOCKET IS ALWAYS UNDER POWER WHEN THE MACHINE PLUG IS CONNECTED TO POWER SUPPLY

WARNING: BEFORE CONNECTING ELECTRICAL OR PNEUMATIC TOOLS TO THE SUCTION MACHINE CHECK THAT THEY ARE SWITCHED OFF

WARNING: BEFORE TURNING THE ELECTRIC SWITCH ON THE VACUUM MACHINE TO "0" CHECK THAT THE TOOL IS OFF

WARNING: When using electro-tools, do not exceed the power reported on the vacuum cleaner additional socket. Check that the electro-tool input voltage corresponds to what is reported on the technical data plate on the vacuum cleaner. Non-observance of these rules can cause serious accidents and damages to the user, also leading to death. It is necessary that the vacuum machine is connected to a grounded socket.

WARNING: When pneumatic tools are used do not exceed the working pressure of 150 PSI (10 atm) – Danger of air hose explosion

When the job is done disconnect the tool from the vacuum machine

WARNING: Changes in the electrical connection of the vacuum cleaner could cause serious damages, even the death of the operator, and irreparable damages to the vacuum cleaner.

(B1) WHITE SLIDE SWITCH (I II) (optional)

(seleziona le due velocità)

POSIZIONE “I”: low speed

1 user – 1 flexible hose

POSIZIONE “II”: high speed

2 users – 2 flexible hoses

(U) ORANGE INDICATOR LIGHT

Connected to a pressure switch, when it lights means that the cartridge filter (essential filter) is clogged and it must be replaced.

(U1) RED INDICATOR LIGHT

It turns on when the thermal protection that stops the motor is activated. The thermal protection works when the temperature of the air coming out from the motor is about 85°C. The motor overheating is due to an obstructed filter cartridge.

CE DICHIARAZIONE DI CONFORMITA' EC DECLARATION OF CONFORMITY

2006/42/CE - 2004/108/CE - 2011/65/CE

We:

DYNABRADE
8989 Sheridan Drive
Clarence New York 14031-1490

declare under our responsibility that the product to which this declaration relates is
in conformity with the following standards or other normative document(s):
Models: 61402, 61403, 61408, 61409, 61412, 61413

- IEC 60335 -1:2010 + A1:2013 SAFETY
- IEC 60335 - 2 - 69:2012 SAFETY
- EN 60335-2-69 allegato AA CLASS DUST
- IEC 62233: 2008 EMF
- EN 55014 - 1:2006 + A1:2001 + A2:2008 EMC
- EN 55014 - 2:1997 + A1:2001 + A2:2008 EMC
- EN 61000 - 3 - 2: 2006 + A1:2009 + A2:2009 EMC
- EN 61000 - 3 - 3: 2013 EMC

following the provisions of the Directives: 2006/42/EC (Machinery directive) - 2004/108/EC
(Electromagnetic compability EMC) 2011/65/EC (Directive RoHS II)

Person authorised to compile the technical file
DYNABRADE
8989 Sheridan Drive
Clarence New York 14031-1490

Colin F. Brogan

Clarence New York 27/03/2015